

H.264 NETWORK Embedded DVR

USER MANUAL



	CAUTION RISK OF ELECTRIC SHOCK DO NOT OPEN	
---	---	---

CAUTION: TO REDUCE THE RICK OF ELECTRIC SHOCK DO NOT REMOVE COVER. NO USER SERVICABLE PARTS INSIDE.
REFER SERVICING TO QUALIFIED SERVICE PERSONNEL.



The lightning flash with arrowhead symbol, within an equilateral triangle, is intended to alert the user to the presence of uninsulated "dangerous voltage" within the products ' enclosure that may be of sufficient magnitude to constitute a risk of electric shock



The exclamation point within an equilateral triangle is intended to alert the user to the presence of important operating and maintenance (servicing) instructions in the literature accompanying the appliance.

WARNING: TO PREVENT FIRE OR SHOCK HAZARD, DO NOT EXPOSE THIS UNIT TO RAIN OR MOISTURE.

CAUTION: TO PREVENT ELECTRIC SHOCK, MATCH WIDE BLADE OF THE PLUG TO THE WIDE SLOT AND FULLY INSERT.

CONTENT

1 INTRODUCTION	4
1.1 MAIN FEATURE	4
1.2 PRODUCT FEATURES	4
1.2.1 PARAMETER (4/8CH)	4
1.2.2 BASIC WORKING PARAMETER	5
1.3 ENVIRONMENT ADAPTABILITY	6
2. DEVICE OPERATION MANUAL	7
2.1 REMOTE CONTROL	7
2.2 MOUSE OPERATION	8
2.2 USING THE SUB-MENU	9
2.3 PLAYBACK	10
2.4 SYSTEM OPERATION	11
2.4.1 USER LOGIN	11
2.4.2 USING THE MAIN MENU	12
3. REMOTE SURVEILLANCE SOFTWARE	33
3.1 FEATURE	33
3.2 USING REMOTE SURVEILLANCE	34
3.3 REMOTE SURVEILLANCE MAIN SCREEN	35
3.3.1 LIVE VIEWING	36
3.3.3 REMOTE SETUP	41
4. DVR INSTALLATION GUIDELINE	45
4.1 FRONT PANEL	45
4.2 REAR PANEL	46
4.3 FULL CONNECTIVITY DIAGRAM	48
4.4 HDD INSTALLATION	49
5. FAQ	50

1 INTRODUCTION

1.1 MAIN FEATURE

4 channels CIF/HD1/D1 (8-channels model only CIF resolution) resolution digital video recorder. It has local recording, playback, support triple code remote network surveillance, data backup, parameter setting, motion detection and USB mouse.

1.2 PRODUCT FEATURES

- ✧ H.264 compression
- ✧ Two USB interface, USB2.0 for data backup, USB1.1 for mouse operation.
- ✧ 3.5" SATA HDD.
- ✧ Special file system for security.
- ✧ 16 bit color translucent user-friendly GUI, with notes for selected menu items
- ✧ Optimized four channel simultaneously playback
- ✧ Double level user management
- ✧ Support live view, parameter setting and copy playback video via network.

1.2.1 PARAMETER (4/8CH)

Item	Device Parameter	Specification
System	Language	English/ Chinese
	GUI	Graphic menu(OSD Menu)
	password	user password, administrator password
Video	Video in	4/8ch composite video input 1.0Vp-p, impedance75Ω, BNC
	Video out	1ch composite video output, BNC (4 CH) 2ch composite video output, BNC (8 CH)
	Video display	4ch:1/4channel switch(8channel:1/4/9 channel)
	Video standard	PAL, 25f/s, CCIR625line, 50scene NTSC, 30f/s, CCIR525line, 60scene
Audio	Audio input	4/8ch audio input, impedance600Ω, RCA
	Audio output	1ch audio output, impedance600Ω, RCA
	Basic electricity output	Linearity electricity
	Record style	Audio video recorded simultaneously
	Audio compression	ADPCM
Picture proceeding and store	Picture compression	H.264
	Picture resolution	CIF/HD1/D1 (8channel only CIF)

	Streaming style	ISO14496-10
	Audio style	ADPCM
	Video code rate (4CH)	CIF: 384~768 Kbps(normal) HD1:512~1024Kbps(high) D1:512~1024Kbps(highest)
	Video code rate (8CH)	CIF: 384 Kbps(normal) CIF: 512 Kbps(high) CIF: 768 Kbps(highest)
	Audio code rate	32KB/s
	Data storage	SATA HDD storage(optional)
Connector	Network interface	RJ45, 10M/100M
Alarm	Alarm input	4/8 alarm input
Connector	Alarm output	1 alarm output
	Serial interface	Support 1 RS232
	Serial interface	Support 1 RS485
	Network interface	RJ45, 10M/100M
Software upgrade	Support USB firmware upgrade	
others	Voltage input	AC:110~240V
	Voltage output	DC: 19V@3.42/3A(optional)
	Power Consumption	6W without HDD
	Working temperature	-10----50℃

1.2.2 BASIC WORKING PARAMETER

Item	Parameter	description
Voltage input	19V	DC 19V
Voltage output for camera	12V (+/-0.2)	4channel :12V@2A (8ch W/O)
Video impedance input	75Ω	75Ω each channel
Video output	1Vp-p	1Vp-p CVBS signal
SATA HDD		One SATA with mainstream capability
Working temperature	-10----50℃	Under normal conditions

1.3 ENVIRONMENT ADAPTABILITY

For safety while using the DVR and to prolong device life, please pay attention to the following details:

- 1) When installing device, please comply with all the electric product safety criteria.
- 2) Power and ground:
 - ◆ Do not touch the power and DVR with a wet hand
 - ◆ Do not drop liquid on DVR
 - ◆ Do not put any object on DVR
 - ◆ Please use soft dry cloth to clean DVR; do not use chemical impregnant.
 - ◆ The Device will have voltage before startup if the power line is connected to power source.
 - ◆ Please unplug power line from power source if the Device is not intended to be used for a prolonged time.











2. DEVICE OPERATION MANUAL

In device operation, the enter key on remote control has the same function as left click of the mouse.

2.1 REMOTE CONTROL

The remote control is the secondary input device
For navigating the system's interface.

To use the remote control:

1. **STANDBY**: Press to turn standby mode ON/OFF.
2. **LOGIN/LOCK**: If "Security" has been enabled in the ISetup menu, press to open the user password login screen.
3. **Number/Channel buttons**: While in menus, press buttons 0~9 to enter values; during live viewing, press to view channels in full-screen.
4. : Press to switch between quad and split-screen displays.
5. **MENU**: Opens the main menu.
6. **PTZ**: Press to open the PTZ control window.
7. **EXIT**: Close menu windows.
8. **Navigation/OK**:
 - : Move cursor in menus up;
 - : Move cursor in menus right;
 - : Move cursor in menus left;
 - : Move cursor in menus down;
 - **OK**: In menus, press to confirm selections; during playback and preview, press to view system information
9. **+ / -**: In menus, press to adjust values.
10. **RECORD**: Press to start manual recording.
11. **STOP**: Press to stop manual recording.
12. **EXTRA**: For the future use.
13. **Playback controls**:
 - : Increase reverse playback speed 1X, 2X, 4X
 - : Press to start playback
 - : Press to increase forward playback speed 1X, 2X, 4X
 - : Press to slow playback speed by 1/2, 1/4, 1/8
 - : Press to freeze playback to one frame, then press again to advance frame-by-frame

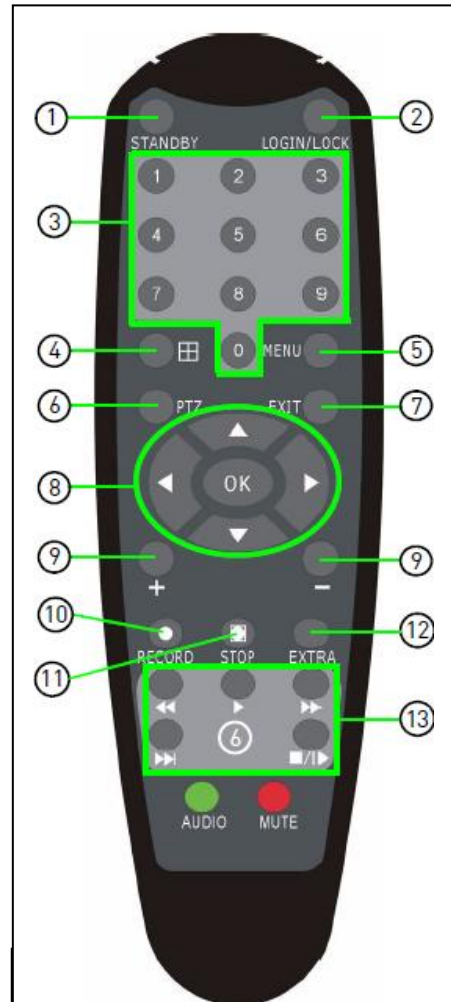

control to enter password and camera titles, select the field using the navigation buttons, press ENTER, and then press the number buttons.

2.2 MOUSE OPERATION

The mouse is the primary input device for navigating system menus.

NOTE: Unless otherwise noted, all system functions described in this manual are achieved through mouse input.

To use a mouse with the system:

- 1) Connect a USB mouse to the **USB MOUSE port** on front panel of the system.

NOTE: Only the top USB port on the front panel is designed for data backup to a USB flash drive. Do not connect a USB flash drive to the bottom USB port on the rear panel.

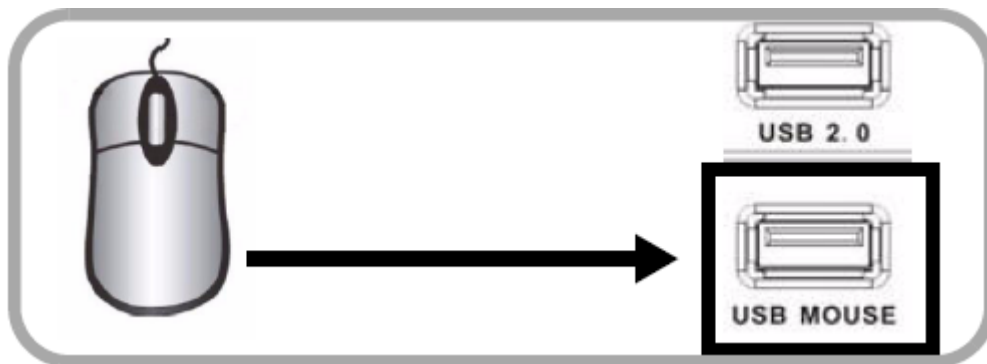

Figure 1.0 Connect a USB mouse to the bottom USB port on the front panel

- 2) Use the mouse buttons to perform the following:
 - **Left-Button:** Click to select a menu option; during live viewing in split-screen, double-click on a channel to view the selected channel in full-screen.; double-click the channel again to return to split-screen view
 - **Right-Button:** Click to open the Sub-Menu
- 3) **Scroll-Wheel:** No function.

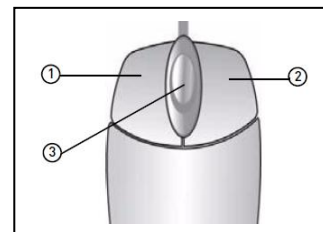

Figure 1.1 Mouse button operation

2.2 USING THE SUB-MENU

Mouse Only

When using the mouse, use the Sub-Menu to access several system options, including the Main Menu and PTZ control.

To open the Sub-Menu:

- 1) Right-click anywhere onscreen. The Sub-Menu opens.



- 2) Select one of the following options:
 - **MAIN MENU:** Opens the main system menu
 - **KEYLOCK:** Locks buttons on the front panel
 - **CHN SWITCH:** Select type of split-screen display
 - **VIDEO SEARCH:** Open the Search Menu to view recorded video
 - **PTZ:** Opens the PTZ control menu
 - **MUTE:** Mute listen-in audio on the system
 - **MANUAL REC:** Start manual recording
 - **STOP REC:** Stop manual recording
- 3) To close the Sub-Menu, click anywhere onscreen.

2.3 PLAYBACK

View recorded video on the system through the Search Menu.

To begin playback:

- 1) Right-click anywhere onscreen and select **VIDEO SEARCH**. The Search Menu opens.

NOTE: When you first open the Search Menu, it displays the current month and date.

- 2) Click **PLAY** to playback the last minute of recorded video (Quick Search).

OR

- 3) Under CHN select a **specific channel** or select **ALL**.

- 4) Under DATE, enter a **date** using the Virtual Keyboard (mouse only).

- 5) Click **SEARCH**. Recorded events on the system appear in red (alarm events—includes both alarm and motion events) and green (normal recording).

- 6) Click a **date** in the Month Grid to search for video files.

- 7) Click a **time block** in the Hour Grid to view the video. Playback begins.

ATTENTION: Only single channel full-screen playback is available on 8-channel models; 4-channel models have full-screen and quad-screen playback.

- 8) Move the mouse slightly to display the onscreen playback controls. You can also use the playback control buttons on the remote control or front panel of the system.

Onscreen Playback Controls

To use the onscreen playback controls:

- 1) Click the VCR-like controls to play, pause, fast forward, rewind, and slow down playback.
- 2) Drag the slider to adjust the volume (audio capable camera required, not included). Select the box to mute the audio.
- 3) Click **X** to quit playback and return to the Search menu.

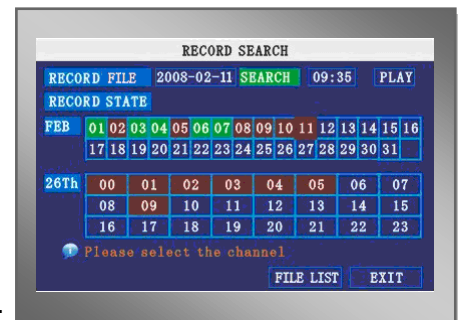
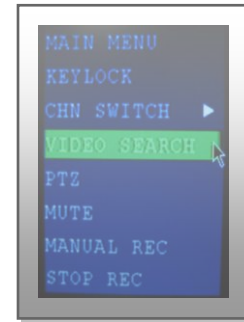

2.4 SYSTEM OPERATION

2.4.1 USER LOGIN

1. STARTING THE SYSTEM

To power the system ON/OFF:

Connect the power cable to the DC 19V port on the rear panel. At startup, the system performs a basic system check and runs an initial loading sequence. After a few moments, the system loads a live display view.

Standby Mode

The system can also be put into Standby Mode. Power will remain to the system but will not be recording.

To start/stop Standby mode:

- 1) Press and hold the **POWER** button on the front panel or remote control until the prompt closes. The system enters standby mode.
- 2) Press and hold the **POWER** button on the front panel or remote control until the system beeps. The system will begin powering up.

Password

ATTENTION: By default, passwords are **disabled** on the system. You do not need to enter a password when accessing any system menus. However, for security purposes, it is highly recommended to enable passwords on the system using the Password Menu.

NOTE:

- 1) If there is no HDD in device, or the device didn't read the HDD, or the HDD didn't be formatted it will display an **【H】** in the video preview interface.
- 2) You must format the HDD in the DVR before first using. The steps as follows: menu > HDD management > format. After formatting, the system will restart.

2. SYSTEM LOGIN

To open the Main Menu:

Right-click anywhere onscreen to open the Sub-Menu and select **MAIN MENU** (mouse only), or press the **MENU/EXIT** button on the remote control or front panel of the system.

NOTE: If passwords are enabled on the system, you need to select your Device ID and enter the 6-digit numerical password to open the Main Menu.



Figure 2.4.1 user login menu

2.4.2 USING THE MAIN MENU



Figure 2.4.2 main menu

- 1) **SEARCH:** Search for recorded video on the system.
- 2) **RECORD:** Configure recording parameters (quality, resolution), set record modes, and enable/disable audio recording.*
- 3) **HDD:** Display hard drive status and format the internal hard drive of the system.
- 4) **BASIC:** Open the Basic Setup Menu, which lets you set the system language, date and time, Device IDs and passwords, and configure audio and video settings.
- 5) **ADVANCE:** Opens the Advanced Setup Menu, which lets you view system info, configure alarm, PTZ, mobile, and network settings.
- 6) **EXIT:** Closes the Main Menu.
- 7) Displays information about the contents of the selected Main Menu icon.

*Audio capable cameras (not included) are required for audio recording on the system.

1 SEARCH



Search and playback recorded video on your system.



Figure 2.4.2.1 Record search menu

NOTE: When you first open the Search menu, it will display the current month and date.

To perform a Quick Search:

Open the Search menu and click **PLAY**. The last minute of recorded playback begins.

To perform a Date & Time search:

- 1) Under CHN, select individual channels or select ALL.
- 2) Under DATE, click the field and enter the desired date using the Virtual Keyboard and then click SEARCH. The system searches for data.
- 3) Under RECORD STATE, the system shows recorded events in a Month Grid and a Time Grid. The selected day of the month will be outlined in red. Green=normal recording; Red=alarm recording (includes both alarm and motion events).
- 4) Click a date in the month grid to view recorded video files for that selected date in the hour grid.

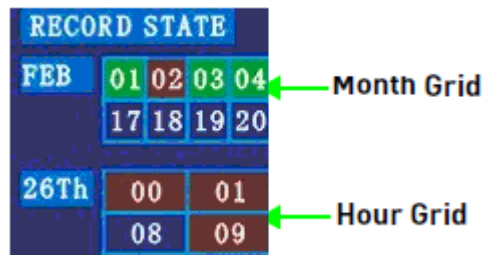

Figure 2.4.2.1.1 record grid

- 5) During playback, use the onscreen controls or the playback buttons on the remote control or front panel to control playback.

FILE LIST

Use the File List sub-menu to see a detailed list of all the recorded video on your system.

To open the File List:

- 1) From the Search Menu, click **SEARCH** to search the system for recorded video.
- 2) Click **FILE LIST** at the bottom of the menu. The File List menu opens.



Figure 2.4.2.1.2 file list menu

To use the File List:

- 1) Under TYPE, select **NORMAL** to view only normal recordings, **ALARM**, to view alarm recordings (includes alarm and motion detection), or **ALL** to view all video on your system.
- 2) Use the buttons on the side panel to navigate the file list:
 - **FIRST**: Jump to the first page of the list
 - **PRE**: Turn to the previous page
 - **NEXT**: Turn to the next page
 - **LAST**: Jump to the last page of the list
 - **ALL**: Select all files

- **OTHER:** Clear all files
 - **BACKUP:** After selecting a file(s), click to begin copying the data to a USB flash drive (not included);
- 3) Click any file to begin playback.

2 BACKUP

Use the File List sub-menu to find recorded video on your system and copy it to a USB flash drive (not included).

NOTE: The system is compatible with most major brands of USB flash drives, with capacities from 256 MB to 4 GB.

To backup recorded data:

- 1) Connect a blank USB flash drive to the top USB port on the front panel of the system.
- 2) Open the Search menu and search for recorded data on the system.
- 3) Click **FILE LIST**.
- 4) Select the files you want to backup and click the "BAK" box next to the file name (see figure 0.0). Select multiple files if desired. Click **ALL** to select all files; click **OTHER** to deselect all files.

NOTE: The size of each file is shown in the File List menu. Use this to help you find a USB flash drive large enough to hold all the files you wish to backup.

- 5) Click **BACKUP** from the side-panel to immediately begin copying the files to the USB flash drive.

NOTE: Backup progress appears in the status window. **DO NOT** remove the USB flash drive during backup.

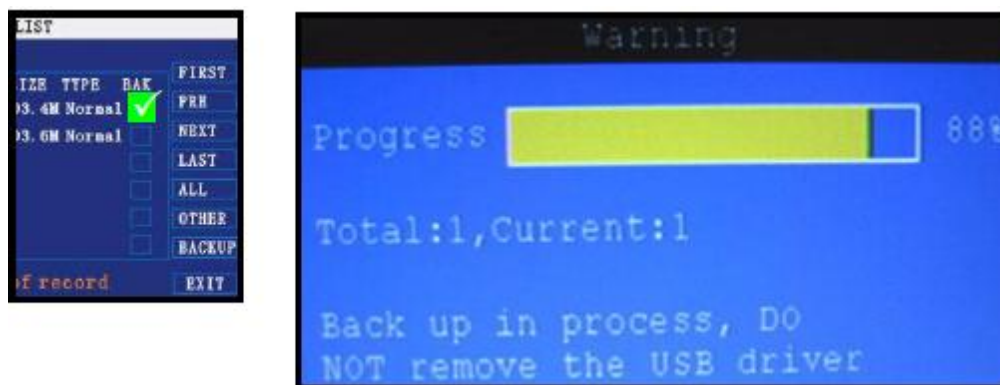

Figure 2.4.2.2 backup

Instruction:

- 1) When the space in backup device is less than recording file, the system will prompt "Space not enough"...
- 2) You can remove USB device directly when backup is finished

3 RECORD MODE



Configure record parameters, enable/disable audio.

NOTE: Audio capable cameras (not included) are required for audio recording.



Figure 2.4.2.3.1 Record (DVR-4CH)



Figure 2.4.2.3.2 Record (DVR-8CH)

To configure recording options:

- 1) Under **CHANNEL**, use the drop-down menus and select **ON/OFF** to enable/disable recording from the selected channel.
- 2) Under **RESOLUTION**, select **HIGHEST**, **HIGH**, or **NORMAL**.

DVR-4CH: Setup resolution and code rate for recording, there are three options: HIGHEST, HIGH, NORMAL, corresponding to **D1**、**HD1**、**CIF** resolution.

NOTE: PAL: D1@6fps, HD1@12FPS, CIF@24fps;
NTSC: D1@7fps, HD1@15FPS, CIF@30fps;

DVR-8CH: There is no **RESOLUTION** option, Only CIF resolution.

- 3) Under **QUALITY**.

DVR-4CH: Select **BEST**, **FINE**, **NORMAL**, Setup code rate for recording,
CIF: corresponding to **384Kbps** and **512Kbps** and **768Kbps**.
HD1: corresponding to **512Kbps** and **768Kbps** and **1024Kbps**.
D1: corresponding to **512Kbps** and **768Kbps** and **1024Kbps**.

DVR-8CH: Select **HIGHEST**, **HIGH**, or **NORMAL**, Setup code rate for recording, corresponding to **384Kbps**、**512Kbps** and **768Kbps**.

- 3) Under **AUDIO**, select **ENABLE** or **DISABLE**. If audio recording is enabled, the system will record audio from connected audio capable cameras (not included).
- 4) Under **REC. MODE**, select **POWER UP** or **TIMER RECORD**. If you select **POWER UP**, the system will record continuously (Normal Recording) when the system is powered on. If you select **TIMER RECORD**, you have to set a recording schedule on the system.
- 5) Under **REC. SIZE**, select **15MIN**, **30MIN**, **45MIN**, or **60MIN**.
NOTE: Record Size sets the file size for recorded video files on the system. Instead of recording data as one large file, the system will divide the data into blocks of 15, 30, 45, or 60 minutes. This makes the recorded data easier to search.
- 6) Click **APPLY**. Click **CLOSE** in the confirmation window.
- 7) Click **EXIT** in every menu until all windows are closed.

Recording Schedule

By default, the system is set to record continuously. You can program the system to record according to a customized recording schedule.

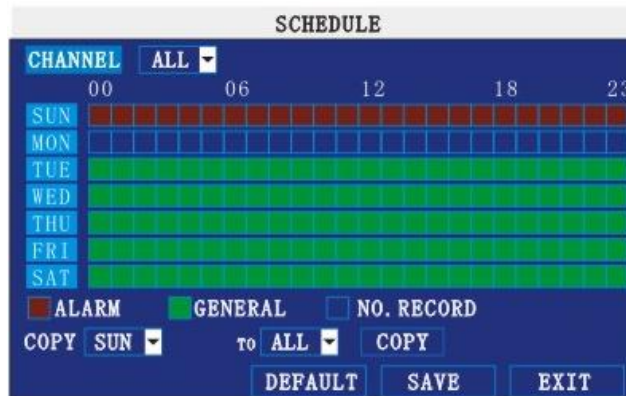

Figure 2.4.2.3.1 Recording Schedule

The Schedule Grid shows the days of the week and hours 0~23. You can set Alarm Recording (Red), General (Normal) Recording (Green), or No Recording (Blue) to each time block of each day.

To set a recording schedule:

- 1) Open the Main Menu and click **RECORD**.
- 2) Under **REC. MODE**, select **TIMER RECORD**.
- 3) Click **SCHEDULE**. The Schedule menu opens.
- 4) Under **CHANNEL**, select specific channels or select **ALL**.
- 5) Below the grid, click either **ALARM** (red), **GENERAL** (Green), or **NO RECORD** (Blue) and then click a time block on the desired day.
- 6) Use the **FROM/TO** drop-down menus to copy the schedule of one day to another. For example, if you want your schedule for Monday to be the same on Wednesday: under **FROM** select **MON**, under **TO** select **WED**, and then click **COPY**.
- 7) Click **SAVE**.
- 8) Click **EXIT** in each menu until all windows are closed.

Example

You want your system to record continuously on all channels from 9 AM to 5 PM

Monday to Friday. You also want Alarm/Motion recording from 5 PM to 9 AM. You do not want the system to record Saturday or Sunday.

NOTE: By default, the system is set to record continuously 24 hours a day, 7 days a week.

To set the recording schedule:

- 1) Open the Schedule menu.
- 2) Under CHANNEL, select **ALL**.
- 3) Click the **blue NO RECORD** block below the grid. A checkmark will appear in the block.
- 4) Under SUN, click blocks **00~23**. The blocks will turn blue.
- 5) Under FROM, select **SUN**. Under TO select **SAT**, and then click **COPY**.
- 6) Click the **red ALARM** block below the grid.
- 7) Under MON, click blocks **00~08** and blocks **18~23**. The blocks will turn red.
- 8) Under FROM, select **MON**. Under TO select **TUE**, and then click **COPY**. Repeat for Wednesday, Thursday, and Friday. Your completed schedule should be the same as the schedule in Figure 2.4.2.3.2.

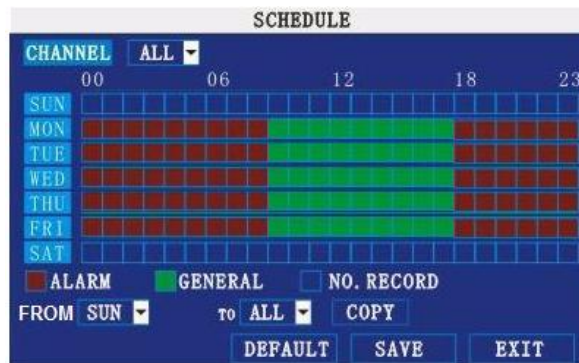

Figure 2.4.2.3.2 Customized recording schedule

- 9) Click SAVE. Click CLOSE in the confirmation window.
- 10) Click EXIT in all menus until all windows are closed.

Mask Field Setup

The Mask Field lets you block a specific portion of a channel you do not want recorded or shown on the display screen. This can be useful if you need to conceal a sensitive area being captured by the installed camera.



Figure 2.4.2.3.3 Mask Field Menu

To use the mask field:

- 1) From the Record menu, click **MASK FIELD SETUP**. The Mask Field menu

- opens.
- 2) Choose a channel you wish to apply the Mask Field. Click **NEXT PAGE** if necessary (8-channel models only). Select **ON** from the **SWITCH** drop-down menu.
 - 3) Click **SETUP**. The Mask Menu disappears and the select channel is shown in full-screen.
 - 4) Using the mouse, click and drag the cursor over the area you want to conceal. A single click will produce a small black square.

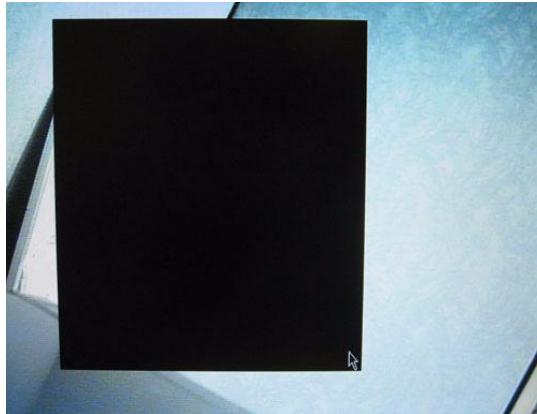

Figure 2.4.2.3.4 Mask Field

- 5) Right-click anywhere on the screen to return to the Mask Field menu.
- 6) Click **APPLY**. Click **CLOSE** in the confirmation window.
- 7) Click **EXIT** in all menus until all windows are closed.

4 HDD MANAGEMENT



Displays essential information about the system's internal hard drive, and lets you format the internal HDD and external USB flash drive (not included).



Figure 2.4.2.4 HDD management menu

The HDD menu displays the following:

- **HDD STATUS:** The system will display "OK" for normal operation
- **SIZE:** The size (in gigabytes) of the internal hard disk drive. The size of your system's internal hard drive will vary by model
- **FREE SPACE:** The space (in gigabytes) remaining on the system's internal HDD
- **AVAILABLE TIME:** The recording time (in hours) remaining on the HDD based on

your current record settings

- **OVERWRITE:** Select **ENABLE** or **DISABLE**. If Overwrite is enabled, the system will record over the oldest video data once the HDD is full. If Overwrite is disabled, the system will stop recording once the HDD is full and the "FULL" LED on the front panel of the system will light up.

Formatting the Hard Drive

ATTENTION: Formatting the HDD will erases all video data. This step cannot be Undone.

Formatting the USB Flash Drive

Use a USB flash drive to backup recorded video and upgrade the system`s firmware. You should always format the USB flash drive you intend to use with the system.

NOTE: Not formatting the USB flash drive may result in improper functionality.

5 BASIC



Set the system language, date and time, passwords, and configure audio and display options.

The Basic Setup menu contains the following sub-menus: **Language**, **Date/Time**, **Password**, **Display**, and **Video/Audio**.



Figure 2.4.2.5 Basic Setup menu

6 LANGUAGE



Figure 2.4.2.6 system language menu

To change the system language:

- 1) From the drop-down menu select **ENGLISH**, or **CHINESE**.
- 2) Click **APPLY**. Click **CLOSE** in the confirmation window.
- 3) Click **EXIT** to close the menu.

NOTE: The device will restart when you finish system language setup.

7 DATA/TIME

It is highly recommended to immediately set the date and time when first setting up your system.

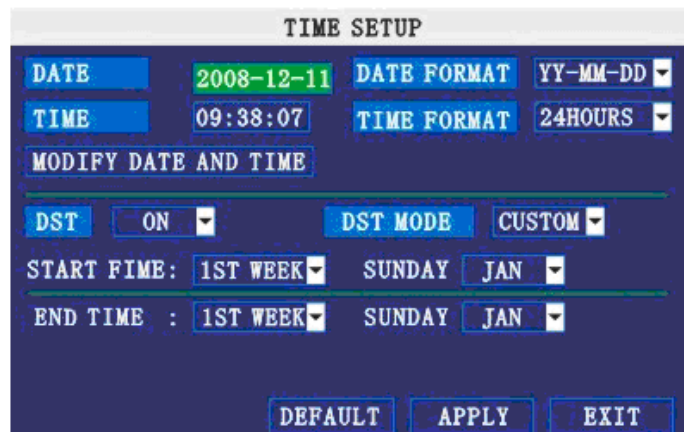

Figure 2.4.2.7 DATE/TIME

To set the date and time:

- 1) Click **DATE/TIME** and configure the following options:
 - **DATE:** Enter the day, month, and year.
 - **DATE FORMAT:** Select **DD/MM/YYYY**, **MM/DD/YYYY**, or **YYYY/MM/DD**
 - **TIME:** Enter the time
 - **TIME FORMAT:** Use the drop-down menu and select **12HOURS** or **24HOURS**
 - **DST:** Use the drop-down menu to select **ON/OFF** to enable/disable Daylight Savings Time
- 2) Click **MODIFY DATE AND TIME**. Click **CLOSE** in the confirmation window.
- 3) Click **APPLY**. The new date and time are saved.

Daylight Savings Time

To set daylight savings time:

- 1) Under DST, select **ON**. DST options appear.
- 2) Under DST MODE select one of the following:
 - **CUSTOM**: Set customized start and end times for DST (go to step 4)
 - **DEFAULT**: The Default setting will apply DST from the second Sunday of March to the second Sunday in November (go to step 3)
- 3) If using the DEFAULT, click **APPLY**.
- 4) If setting a CUSTOM DST, use the drop-down menus to select a week and month for the start and end times.
- 5) Click **APPLY**. Click **CLOSE** in the confirmation window.
- 6) Click **EXIT** in each menu until all windows are closed.

8 PASSWORD

When you first startup your system, you are technically logged in as the ADMIN under Device ID000000. The system employs two user authorities connected to a Device ID. The authorities are as follows:

- **ADMIN**—administrator: Has full control of the system, and can change both administrator and user passwords and enable/disable password checking
- **USER**—normal user: Only has access to live viewing, search, playback, and other limited authorities. For security reasons, it is highly recommended to enable passwords on your system. If you enable passwords, you must select a 6-digit USER password and a 6-digit ADMIN password.

ATTENTION: By default, passwords are disabled on the system. You will not need a password to log in or access menus. You will not need a password to access your system using the browser-based remote software.



Figure 2.4.2.8 password

You can change the Device ID and password of the ADMIN and the USER from the Password menu.

To open the Password/security menu:

- 1) Right-click anywhere onscreen to open the Sub-Menu and select **MAIN MENU**.
- 2) Click **BASIC**. The Basic Setup Menu opens.
- 3) Click **PASSWORD**. The Password/Security menu opens.

To change your Device ID and Password:

- 1) Click the field beside **DEVICE ID** and enter a **6-digit numerical** Device ID using the Virtual Keyboard (mouse only). For example, change the ID to 000010.
- 2) Under **PASSWORD**, select **ENABLE**.
- 3) Click the field beside **USER PASSWORD** to enter a **6-digit numerical password** using the Virtual Keyboard (mouse only). Re-enter the password in the corresponding field.
- 4) Click the field beside **ADMIN PASSWORD** to enter a **6-digit numerical password** using the Virtual Keyboard (mouse only). Re-enter the password in the corresponding field.

NOTE: The USER and ADMIN passwords must not be the same.

- 5) Click **APPLY** to save your changes. Click **CLOSE** in the confirmation window.
- 6) Click **EXIT** in each menu until all windows are closed.

Use your new password to log in to the system and access system menus. You can also use the USER and ADMIN passwords to access your system using the browser-based remote software.

NETWORK PW CLEAN: Select and click **APPLY** will initialize the IE browser password.

9 DISPLAY

DISPLAY

Use the Display Setup menu to customize channel titles, show/hide the date and time in live viewing and playback, and enable/disable preview channels.

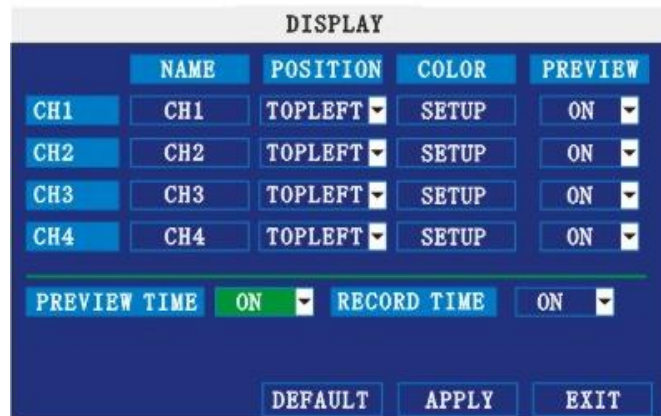

Figure 2.4.2.9 display

To customize Display settings:

- 1) Configure the following options:
 - **NAME:** Click any of the fields and enter a new title for the selected channel using the Virtual Keyboard (mouse only)
 - **POSITION:** Reposition the channel title; select **TOPLEFT**, **BOTTOMLEFT**, **TOPRIGHT**, **BOTTOMRIGHT**, or **OFF**. If OFF, the title will not be displayed for the selected channel
 - **COLOR:** Adjust **CHROMATICITY**, **LUMINOSITY**, **CONTRAST**, and **SATURATION** for the selected channel
 - **PREVIEW TIME:** Select **ON/OFF** to show/ hide the date and time during live viewing
 - **RECORD TIME:** Select **ON/OFF** to show/hide the date and time during

playback.

- 2) Click **NEXT PAGE** to change the settings for the remaining channels (8-channel models only).
- 3) Click **APPLY** to save your settings. Click **CLOSE** in the confirmation window.

Preview

Preview channels can be very useful if your display monitor is in public view. Select **OFF** of a preview channel will appear black on the display to give the impression that no cameras are connected and the system is not recording.

To enable/disable preview channels:

- 1) Choose a channel you wish to conceal. For example, channel 3. Under **PREVIEW**, select **OFF**.
- 2) Click **APPLY**. Channel 3 will turn black. Click **CLOSE** in the confirmation window.
- 3) Click **EXIT** in all menus until all windows are closed.

10 VIDEO/AUDIO

Use the Video/Audio menu to set the resolution and camera system on the system.



Figure 2.4.2.10 Video/Audio menu

To configure video options:

- 1) Under **VGA RESOLUTION**, select **800x600** or **1024x768**.
- 2) Under **CAMERA SYSTEM**, select **NTSC** or **PAL**.
- 3) Click **APPLY**. Click **CLOSE** in the confirmation window.
- 4) Click **EXIT** in all menus until all windows are closed.

To configure audio options:

- 1) From the Video/Audio menu, click **VOLUME SETUP**. A split-screen display view appears.
- 2) Click any channel and adjust the slider to increase/decrease the volume for listen-in audio.
- 3) Click **X** to return to the Video/Audio menu.
- 4) Click **APPLY**. Click **CLOSE** in the confirmation window.
- 5) Click **EXIT** in all menus until all windows are closed.

11 ADVANCE



Use the Advanced Setup menu to configure alarm settings, motion detection, mobile surveillance, PTZ settings and network settings. The Advanced Setup menu contains the following sub-menus: **Alarm**, **Info**, **MD**, **Mobile**, **System**, **PTZ**, and **Network**.



Figure 2.4.2.11 Video/Audio menu

12 ALARM

Use the Alarm menu to configure alarm and email settings.

NOTE: External alarm devices must be connected to the alarm block on the rear panel of the system in order to use the I/O (input/ output) alarms of the system.

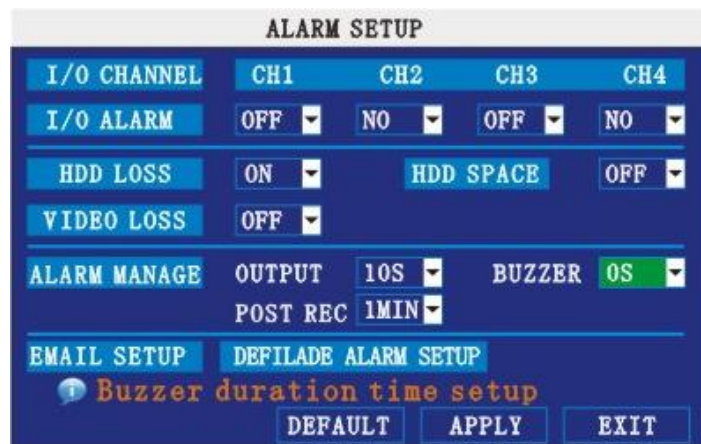

Figure 2.4.2.12.1 Alarm setup menu

To configure alarm settings:

- 1) Under I/O CHANNEL, select **NO** (Normal Open), **NC** (Normal Closed), or **OFF**. Click **NEXT PAGE** to view additional channels (8-channel models only).
- 2) Apply loss alarms to the following:
 - **HDD LOSS:** The alarm will sound if the internal HDD is damaged
 - **HDD SPACE:** The alarm will sound when the HDD is full (overwrite must be disabled)
 - **VIDEO LOSS:** The alarm will sound when a camera is disconnected
- 3) Under ALARM MANAGE, configure the following:
 - **OUTPUT:** Set the output time (in seconds) on the spot monitor from **0s**, **10s**,

20s, 40s, or 60s.

- **BUZZER:** Set the time (in seconds) for the buzzer when an alarm is triggered—**0s, 10s, 20s, 40s, or 60s**

NOTE: Set the buzzer to **0s** if you want to disable the alarm during motion detection

- **POST REC:** Set the time (in seconds) for the system to record after a triggered alarm—**0s, 10s, 20s, 40s, or 60s**

- 4) Click **APPLY**. Click **CLOSE** in the confirmation window.

EMAIL SETUP:

The system can send an email notification with a JPEG snapshot for triggered events on the system.

Figure 2.4.2.12.2 Email Setup menu

To setup email notification:

- 1) Under **EMAIL**, select **ON**.
- 2) Under **SSL**, select **OFF**.

NOTE: SSL deals with encryption. Only advanced users should enable this option.

- 3) Under **SMTP PORT**, enter the **SMTP port** of your email server.
- 4) Under **SMTP**, enter the **SMTP** address of your email server. For example, **smtp.gmail.com**
- 5) Under **SEND EMAIL**, enter the sender email address.
- 6) Under **SEND PW**, enter the **password** of your email server.
- 7) Under **RECV EMAIL**, enter the email address that will receive the email notification.
- 8) Click **APPLY**. Click **CLOSE** in the confirmation window.
- 9) Click **EXIT** in all menus until all windows are closed.

13 SYSTEM INFO

View system information, including the firmware version, MAC address, and serial number of the system.

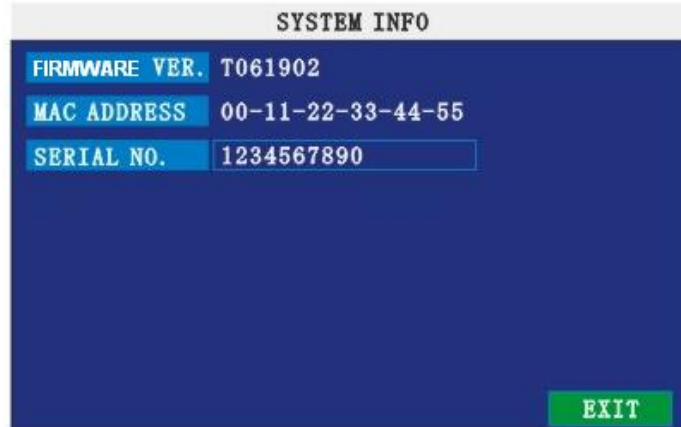

Figure 2.4.2.13 System info

14 MOTION DETECT

Configure motion detection for each channel.

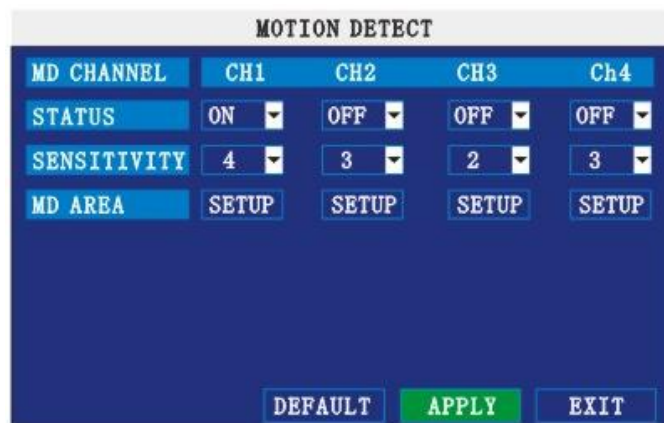
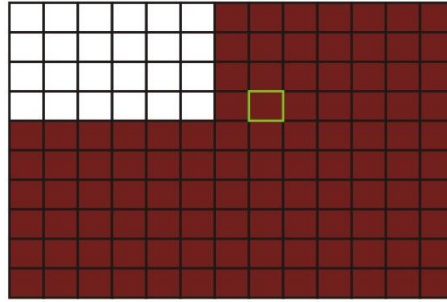

Figure 2.4.2.14 Motion detect

To configure motion detection:

- 1) Under STATUS, select **ON** to enable motion detection for the desired channel. Click **NEXT PAGE** for additional channels (8-channel models only).
- 2) Under SENSITIVITY, select **1**, **2**, **3**, or **4**. The higher the number, the more sensitive the motion detection.
- 3) Under MD SETUP, click **SETUP**. The red motion grid appears over the selected channel in full screen.
- 4) Click the blocks in the grid to enable/disable motion detection. Red=motion detection enabled; Clear=motion detection disabled.



- 5) Right-click anywhere on the screen to return to the Motion Detection menu.
- 6) Click **APPLY**. Click **CLOSE** in the confirmation window.
- 7) Click **EXIT** in all menus until all windows are closed.

NOTE: You can disable the MD buzzer in the Alarm Setup menu.

15 MOBILE

Send alerts to your cellular phone Windows Mobile enabled touch-screen smart phone (Windows Mobile 6.0 or greater, S60 3rd or greater is required).

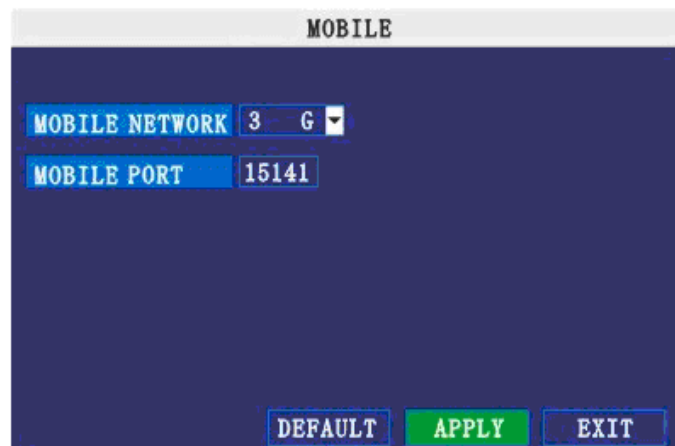

Figure 2.4.2.15 mobile

To configure mobile notification settings:

- 1) Under MOBILE NETWORK, select **3G, 2.75G**, or **2.5G**.

NOTE: Contact your cellular provider if you are unsure about the network of your cellular phone.

- 2) Under MOBILE PORT, enter your mobile port number.
- 3) Click **APPLY**. Click **CLOSE** in the confirmation window.
- 4) Click **EXIT** in all menus until all windows are closed.

16 SYSTEM

Use the System menu to update system firmware and set an automatic system reset schedule.

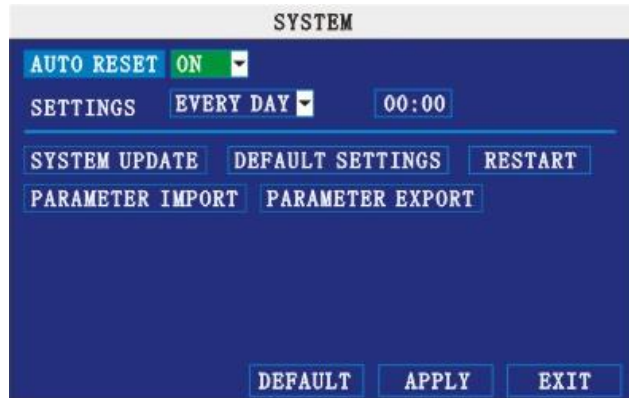

Figure 2.4.2.16 system

To enable auto-reset:

- 1) Under AUTO RESET, select **ON**. The Settings option appears.
- 2) Under SETTINGS, select **EVERY DAY**, **EVERY WEEK**, or **EVERY MONTH**. The date drop-down menu appears.
- 3) Select the date for auto-reset from the drop-down menu.
- 4) Enter the time for auto-reset using the Virtual Keyboard (mouse only).
- 5) Click **APPLY**. Click **CLOSE** in the confirmation window

To restore factory settings:

- 1) Click **DEFAULT SETTINGS**. This will restore the system to the original factory settings.
- 2) Click **OK** in the prompt.

NOTE: Recorded video on the HDD will not be erased.

To restart the machine (soft-reset):

- 1) Click **RESTART**.
- 2) Click **OK** in the prompt. The system will perform a soft-reset and load to a live split-screen view.

To upgrade firmware:

- 1) Copy the firmware file to an empty USB flash drive. The firmware file should not be in a folder.
- 2) Connect the USB flash drive to the top USB port on the front panel of your system.
- 3) Open the System Menu (Main Menu>Advance>**System**).
- 4) Click **FIRMWARE UPDATE**. The system will scan the USB flash drive and begin updating the firmware. Do not remove the USB flash drive while the upgrade is taking place.

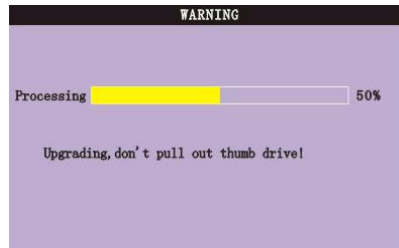

- 5) Click **CLOSE** in the confirmation window. In the system prompt, click **OK**. The system will restart.

PARAMETER EXPORT: Copy the system settings of the device to an empty USB flash drive.

PARAMETER IMPORT: Import system settings from another device.

17 PTZ

Use the PTZ Setup menu to configure settings for a connected PTZ camera (not included).

NOTE: Consult the instruction manual of your PTZ camera for complete information about your camera, including protocol and baud rate.



Figure 2.4.2.17 PTZ setup

To configure a PTZ camera:

- 1) Connect a PTZ camera to the BNC and 485A (TX, +) and 485B (RX, -) ports and power outlet. For more details on connecting a PTZ camera.
- 2) Under PROTOCOL, select **PELCO-D** or **PELCO-P** for the selected channel. Click **NEXT PAGE** for additional channels (8-channel models only).
- 3) Under BAUD RATE, select **1200**, **2400**, **4800**, or **9600**.
- 4) Under DATA BIT select **5**, **6**, **7**, or **8**.
- 5) Under STOP BIT, select **1** or **2**.
- 6) Under VERIFY, select **ODD**, **EVEN**, **MARK**, **SPACE**, or **NONE**.
- 7) Under ADDRESS, enter an address from **001~255** using the Virtual Keyboard. Refer to your PTZ camera's instruction manual for further details.
- 8) Click **APPLY**. Click **CLOSE** in the confirmation window.
- 9) Click **EXIT** in all menus until all windows are closed.

18 NETWORK

Use the Network Setup menu to configure your network and DNS settings.



Figure 2.4.2.18.1 network setup

UPNP

UPnP Forum is an industry initiative designed to enable simple and robust connectivity among consumer electronics, intelligent appliances and mobile devices from many different vendors. As a group, we are dedicated to making the connected home and lifestyle mainstream experiences for consumers - and great opportunities for the industry.

NOTE: Need your Router to support **UPNP** function.

To configure **UPNP** settings:

- 1) Enable the **UPNP** function in your Router.
- 2) Under DVR GUI, Open the **MAIN MENU** and click **ADVANCE**.
- 3) From the **Advanced Setup** menu, click **NETWORK**.
- 4) Under **UPNP**, select **OPEN**.
- 5) Click **APPLY** to save your settings and then click **OK** in the confirmation window.
- 6) Using a remote PC, open **Internet Explorer**.
- 7) In the address bar, enter your Router WAN IP address immediately followed by :WEB PORT (no spaces).
http://XXX.XXX.XXX.XXX(Router WAN IP):XXX(WEB PORT)
- 8) Enter your system **ADMIN** password and select **INTERNET**.

NOTE: If you have not enabled passwords on the system, leave the password field blank.

- 9) Click **LOGIN**.

To configure network settings:

- 1) Under TYPE, select **DHCP**, **PPPoE**, or **STATIC**. If DHCP, go to step 5. If PPPoE, go to step 2. If STATIC, go to step 3.

NOTE: DHCP allows you to quickly connect to your network by obtaining an IP address from the router. After the initial setup, we recommend that you disable DHCP and set the IP address between 1~100. For example, if your IP address is 192.168.0.107, change the last digits to 90 (i.e. 192.163.0.90). This ensures that port forwarding will not change in the event of power failure or resetting of your network.

- 2) If you select PPPoE in step 1, enter your **PPPoE user name** and **password** in the respective fields using the Virtual Keyboard.

The screenshot shows a 'NETWORK SETUP' window with the following fields and options:

- TYPE:** PPPoE (selected in a dropdown menu)
- MEDIA PORT:** 09000
- WEB PORT:** 00080
- PPPOE NAME:** (empty text field)
- PASSWORD:** (empty text field)
- DNS:** 202.096.134.133
- DDNS SETTINGS:** (button)
- UPNP:** (button)
- OPEN:** (radio button, selected)
- CLOSE:** (radio button)
- DEFAULT:** (button)
- APPLY:** (button, highlighted in green)
- EXIT:** (button)

Figure 2.4.2.18.2 PPPoE

- 3) If you selected STATIC in step 1, enter your **IP Address**, **Net mask**, and **Gateway** in the respective fields using the Virtual Keyboard.

NOTE: The default IP address of the system is 192.168.3.97

- 4) If necessary, change the Media and Web Ports.

NOTE: For added security, we strongly recommend changing Web port 80 on the system to any desired port not blocked by your Internet service provider (ISP). Please note however, that you will also need to update the Web port in your browser and open this new port in your router.

- 5) Click **APPLY**. Click **CLOSE** in the confirmation window.
- 6) Click **EXIT** in all menus until all windows are closed. The system restarts automatically.

Manual DNS

Enter the **Primary or Secondary DNS** from your router. This is required for DDNS to function properly.

To obtain your Primary or Secondary DNS:

- 1) In your web browser, log in to your router using its Default Gateway address.

NOTE: Refer to your router's manual or software for login information. You can also get the Default Gateway on your PC by selecting Start>Run. Type **CMD** and press **Enter**. In the Command Prompt window type **ipconfig** and press Enter.

- 2) View its **WAN settings**. Enter the **Primary or Secondary DNS** address in the **MANUAL DNS** field on your system.

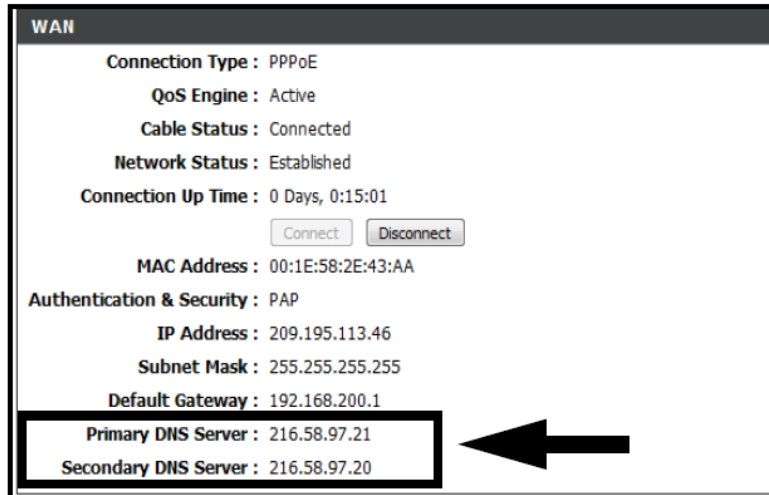

Figure 2.4.2.18.3 Manual DNS

DDNS:

A DDNS account allows you to set up a web site address that points back to your Local Network.

NOTE: You must register DDNS service prior to configuring DDNS settings. Visit <https://www.dyndns.com/> to register.



Figure 2.4.2.18.4 DDNS

To configure DDNS settings:

- 1) From the Network Setup menu, enter **Primary or Secondary DNS** from the WAN settings of your router in the **MANUAL DNS** field.
- 2) Click **DDNS SETTINGS**.
- 3) Under DDNS, select **ON**.
- 4) Under SERVICE, select 3322, dyndns or perfecteyes.
- 5) Under DOMAIN NAME, enter **your DDNS domain** from the confirmation email. **For example**, if your domain name is adam@dyndns.com, you need to enter adam@dyndns.com, in the text field.
- 6) Enter your DDNS **user name** and **password** in the respective fields.
- 7) Click **APPLY**. Click **CLOSE** in the confirmation window.
- 8) Click **EXIT**. The system will prompt you that it must restart. Click **CLOSE**.

3. REMOTE SURVEILLANCE SOFTWARE

3.1 FEATURE

The system features a built-in browser-based software that allows you to access your system remotely over your local area network (LAN) or over the Internet using Internet Explorer®.

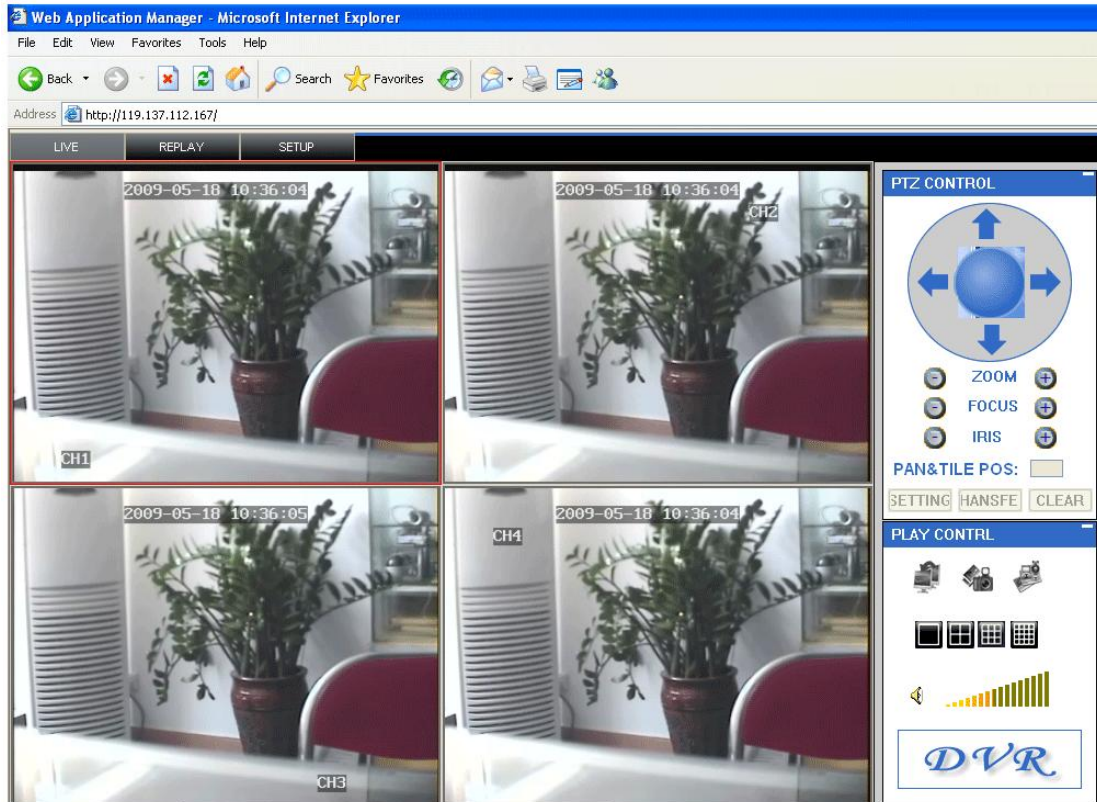

Figure 3.1.0 Remote Surveillance main screen

Install the software through the IE browser of OS and you operate the network remotely and conveniently. DVR supports C/S, B/S, and visit in LAN and WAN, also supports IP and domain name visiting.

RESTRICTION CONDITION:

To ensure PC's stable visiting of DVR, recommend Windows XP, Windows Vista, Windows 7 operation system, recommend browser as IE 6.0, IE 7.0, IE 8.0.

3.2 USING REMOTE SURVEILLANCE

With your system connected to your local area network, you can now log in to your system using Internet Explorer.

NOTE: Your system must be connected to your local or wide area network before attempting remote access.

Logging In to Your System

With your IP address, you can now log in to your system over your local or wide area network.

NOTE: You must configure DDNS settings locally.

To access your system:

- 1) Open Internet Explorer. In the address bar, enter the IP address of your system (i.e. 192.168.3.97).
- 2) You must install the ActiveX® in order to access your system. Click the attention bar at the top of the main page and select **Install ActiveX Control**. DVR Net viewer will reset.

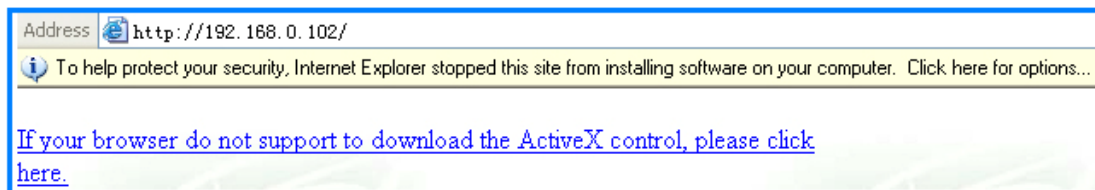

Figure 3.2.1 Click the ActiveX attention bar

- 3) In the warning box click **Install**. The login page appears.
- 4) Leave the password field **blank** (default).

NOTE: If you have enabled passwords on your system, enter your USER or ADMIN password. However, only the ADMIN can change settings and options on the system.

- 5) Select **LAN** or **INTERNET** from the drop-down menu and click **LOGIN**. The process will last for 1~2 minutes.

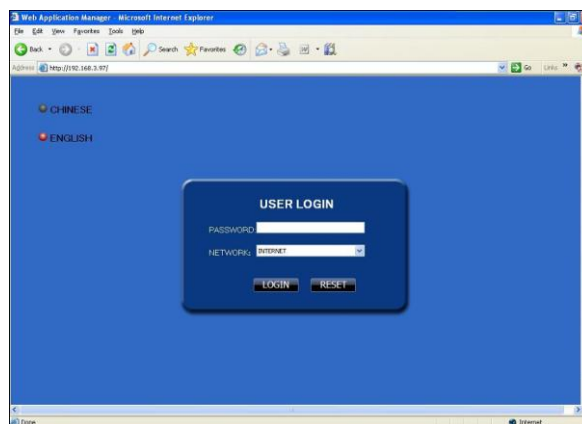

Figure 3.2.2 Remote access login screen

3.3 REMOTE SURVEILLANCE MAIN SCREEN

Upon login, the Remote Surveillance main screen appears in your browser.

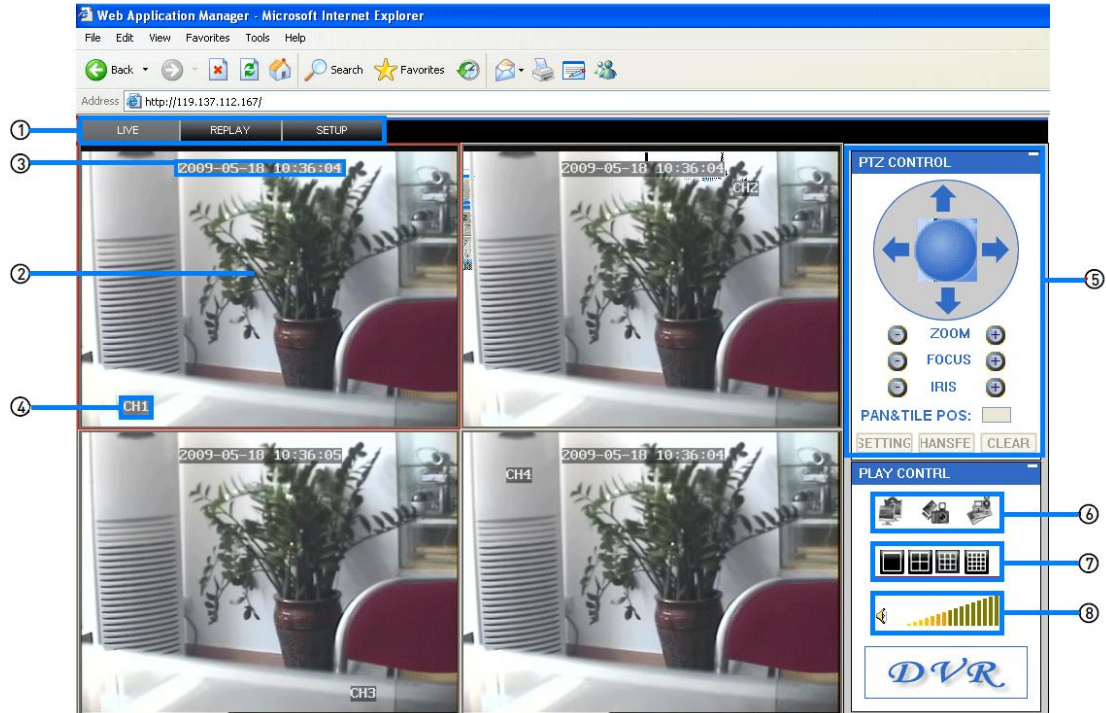

Figure 3.3.0 DVR Net viewer main screen



- 1) **Modes:** Click LIVE, REPLAY (playback), and SETUP.
- 2) **Main Screen:** Main display screen for live viewing and playback.
- 3) **Time Stamp:** Time stamp appears on each channel.
- 4) **Channel:** Channel number appears in the top left corner.
- 5) **PTZ Control:** PTZ control for any connected PTZ cameras (not included).
- 6) **Functions:** Click the icons to show/hide channels, take screen captures, and record.
- 7) **Display Modes:** Click the icons to view channels in single-channel full-screen, quad, and split-screen configurations.
- 8) **Volume/Mute:** Select a channel (outlined in red) and then click the bars to increase/decrease volume; click the icon to mute/unmute volume.*

*Audio capable cameras (not included) required for audio listening and recording.

3.3.1 LIVE VIEWING

By default, remote surveillance opens in Live Viewing mode (split-screen).

To use Live Viewing:

- 1) Click **LIVE** at the top of the main screen.
- 2) Click the display mode icons to view the main screen in **single-channel**, **quad**, or **split-screen** configurations. You can also double-click a channel at any time to view it in single-channel.
- 3) Click  to show or hide all the channel windows.
- 4) Click  to start/stop manual recording to your PC on ALL channels. For more details see RECORDING.
- 5) Select a channel (outlined in red) and then click the audio bars to increase or decrease listen-in volume. Click the icon to mute/unmute.

NOTE: The Talk function is not supported.

*Audio capable camera (not included) required for listen-in audio.

3.3.1.1 RECORDING



You can record video directly to your PC using the remote surveillance software.

To record video to your PC:

From Live viewing, click to start/stop manual recording to your PC on ALL channels

NOTE: You will record video to your PC regardless of the recording mode on the system itself. By default, recorded files are saved in C:\DVR\[ip_address]\Record.

3.3.1.2 SUB-MENU

Right-click any channel to open the sub-menu.



The sub-menu contains the following options:

- **Open Window**
- **Close**
- **Open All**
- **Close All**
- **Start Record**
- **Stop**

3.3.1.3 PTZ CONTROL

You must have a PTZ camera (not included) connected to the system in order to use the PTZ controls.

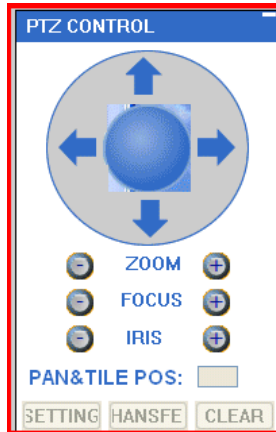

To control a PTZ camera:

1. Select the channel of the connected PTZ camera(s).
2. Click the **navigation arrows** to pan and tilt the camera. 3. Click **+/-** to control zoom, focus, and iris.
4. Enter presets.
5. Click **SETTING**, **HAND**, and **CLEAR** to further control presets.

3.3.1.4 SCREEN CAPTURES

Use the remote surveillance software to take a snapshot of the channels on the main display screen. Screen Captures can be useful for your own records, or may be needed by authorities in case of a security incident.

To take a screen capture:

- 1) From Live Viewing, select the channel you want to capture. The selected channel will be highlighted in a red frame.
- 2) Click .
- 3) Click **OK** in the confirmation window. Screen captures are saved as BMP files to the default save location (C:\DVR\...).

3.3.1.5 PLAYBACK

Use the Replay menu to search and playback recorded video on your system.

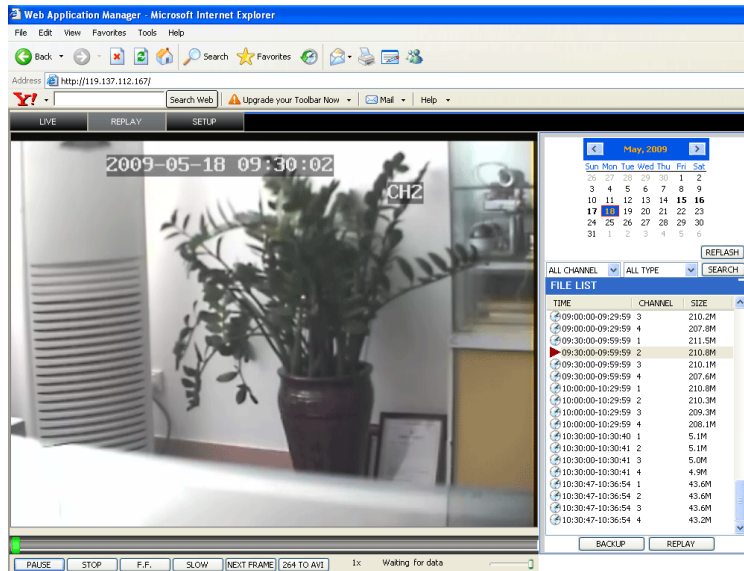

Figure 3.3.1.2.1 Playback screen

To use the replay menu:

- 1) Click **REPLAY** at the top of the main screen. The main screen will be grey.
- 2) Click **REFRESH** below the calendar to view the recorded files for the current month.

NOTE: Normal recording is indicated by a clock icon; alarm recording (alarm, loss, and motion events) are indicated by an exclamation mark icon.

- 3) Double-click a file from the File List to playback the file in the main screen. The icon in the file list changes to "▶". Control playback using the buttons at the bottom of the main screen.

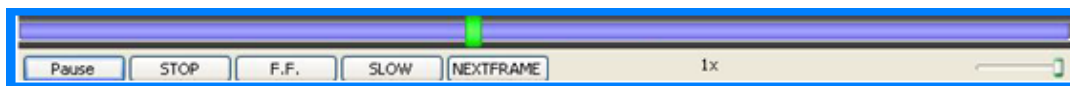

Figure 3.3.1.2.2 Progress bar

The purple bar indicates the download progress. The green marker indicates playback progress. You can click and drag the playback marker (will turn from green to orange) to advance or rewind playback as needed.

Pause	Switch between pause/play
STOP	Stop play
F.F.	Fast play
SLOW	Slow play
NEXTFRAME	Pause at next frame

SEARCH

Use the calendar and drop-down menus to search for recorded video on your system.

- 1) Click < > to change the month on the calendar. Dates with recorded video data will appear in **bold**.
- 2) Click the date. Recorded video files will populate the File List.
- 3) From the Channel drop-down menu, select a **specific channel** or select **ALL CHANNEL** and then click **SEARCH**.
- 4) From the Type drop-down menu, select **COMMON** (normal recording), **ALARM**, or **ALL TYPE** and then click **SEARCH**.
- 5) Double-click the file from the File List to playback the file in the main screen.

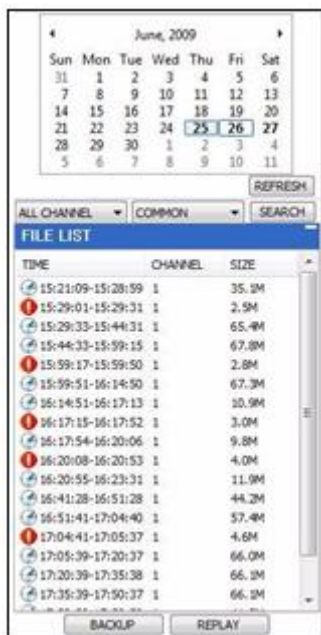

REMOTE BACKUP

You can backup recorded video files from your system to your PC using the Replay menu in the remote surveillance software.

To backup files remotely:

- 1) Click **REPLAY** at the top of the main screen.
- 2) Select a date(s) on the calendar and click **REFRESH**.
- 3) Double-click a file from the File List to begin playback.
- 4) Click **BACKUP**. Backup begins to C:/DVR/[ip_address]/Backup

NOTE: If you playback a file, you must wait for the file to load before backing it up otherwise you may receive an error message

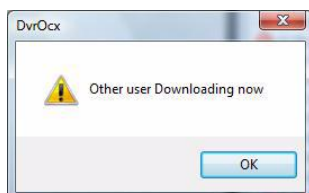

- 5) When file backup is complete, click **OK** in the confirmation window. The confirmation window show the save path of the backup file.

NOTE: Backup files are saved as **.264** files.

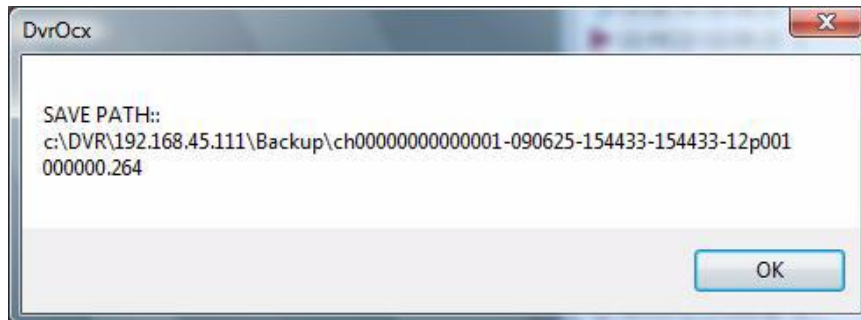

NOTE: Use the Player Software included on the software CD to playback backed up video.

3.3.3 REMOTE SETUP

Use the Setup tab to configure the settings of your system from a remote location.

NOTE: If the Main Menu is open on the system, you will not be able to make changes to the system from the remote location.

To open remote setup:

Click **SETUP** at the top of the main screen. The Remote Setup menu features the following tabbed options:

- **RECORD**
- **ALARM**
- **PTZ**
- **NETWORK**
- **SETTING**
- **HOST INFO**

Click  to enter into setup interface, this interface include record, alarm, PTZ, network, setting and system information six menus.

3.3.3.1 RECORD

Click  to enter into setup interface; you can check the parameter settings as in GUI of DVR.

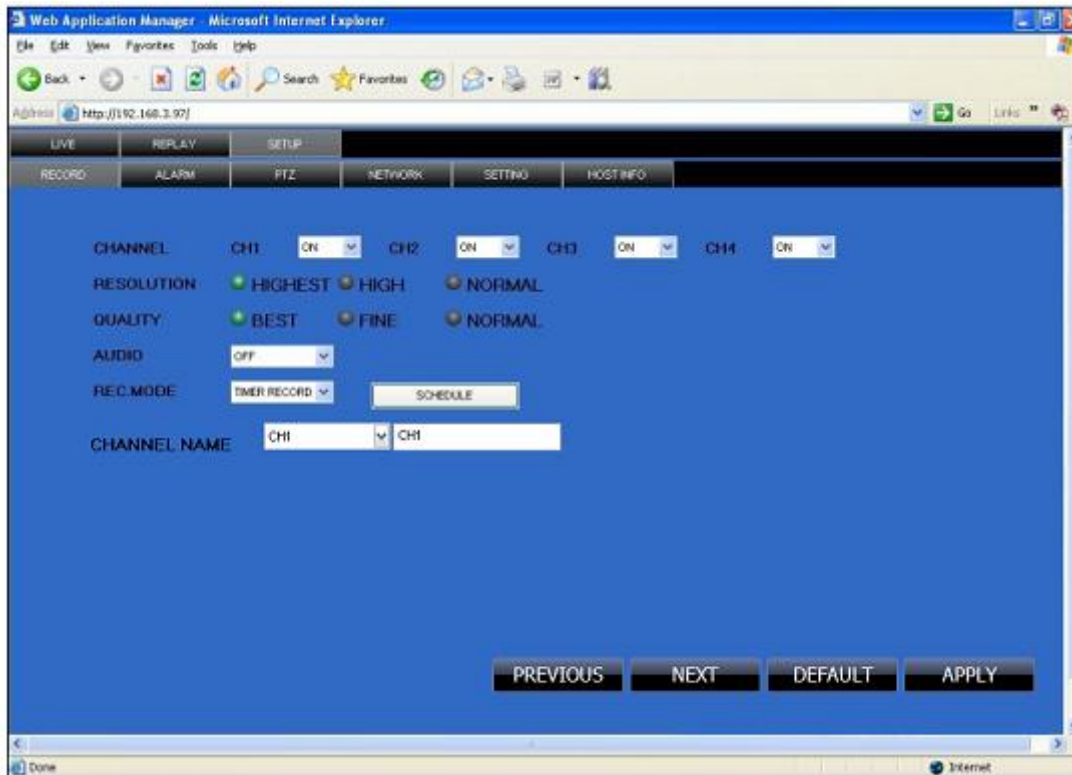

3.3.3.2 ALARM SETTING

Click “ALARM” to enter into setup interface; you can check the parameter settings as in GUI of DVR.

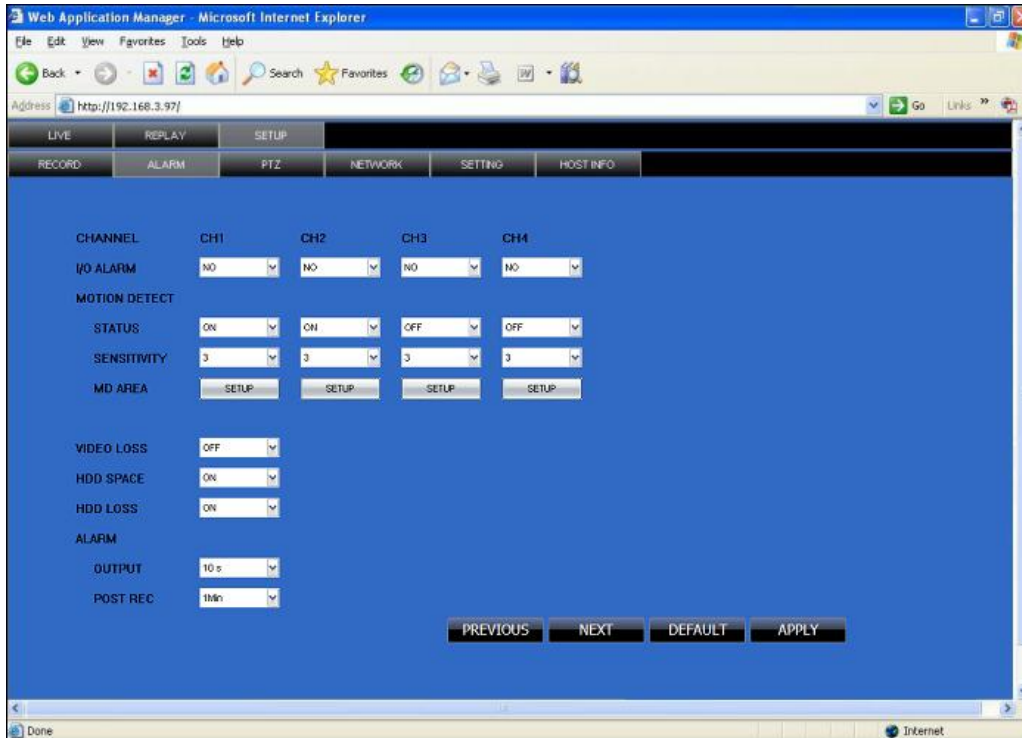

3.3.3.3 PTZ

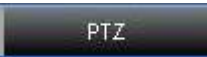
Click  to access setup interface; you can check the parameter settings in GUI of DVR.

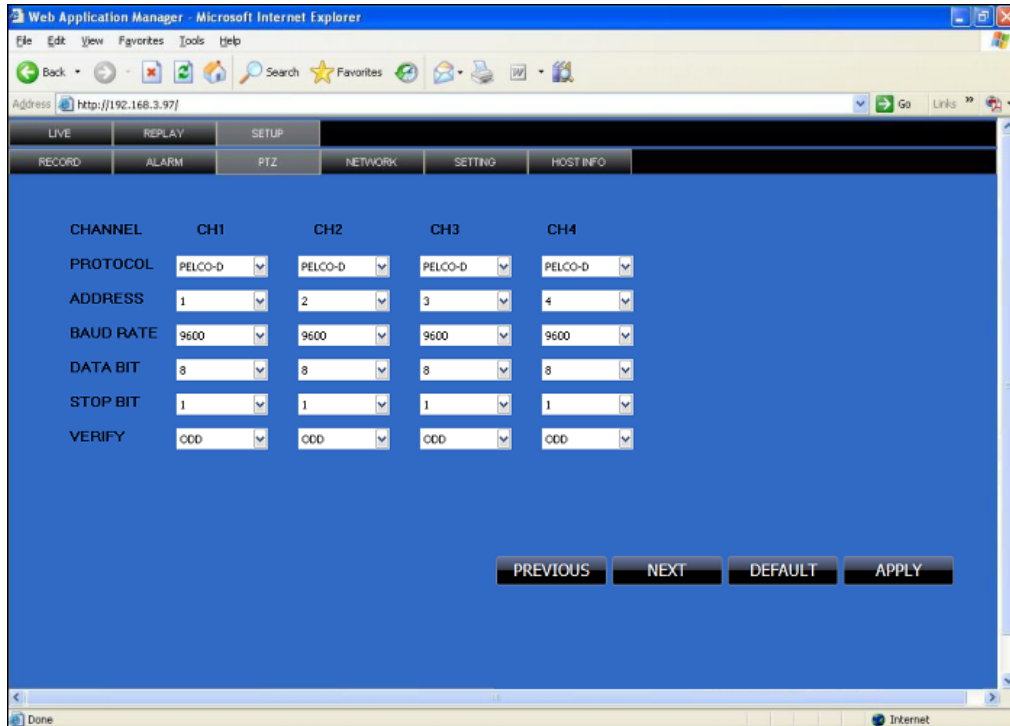

3.3.3.4 NETWORK

Click  to access setup interface; you can check the parameter settings in GUI of DVR.

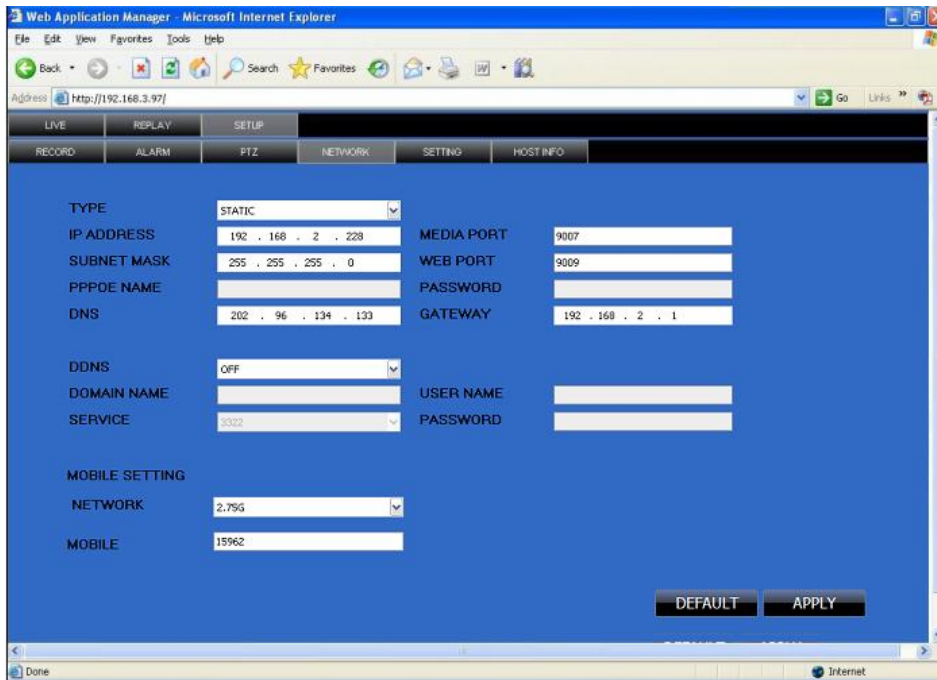

3.3.3.5 SETTING

Click  to access setup interface; you can check the parameter settings in GUI of DVR

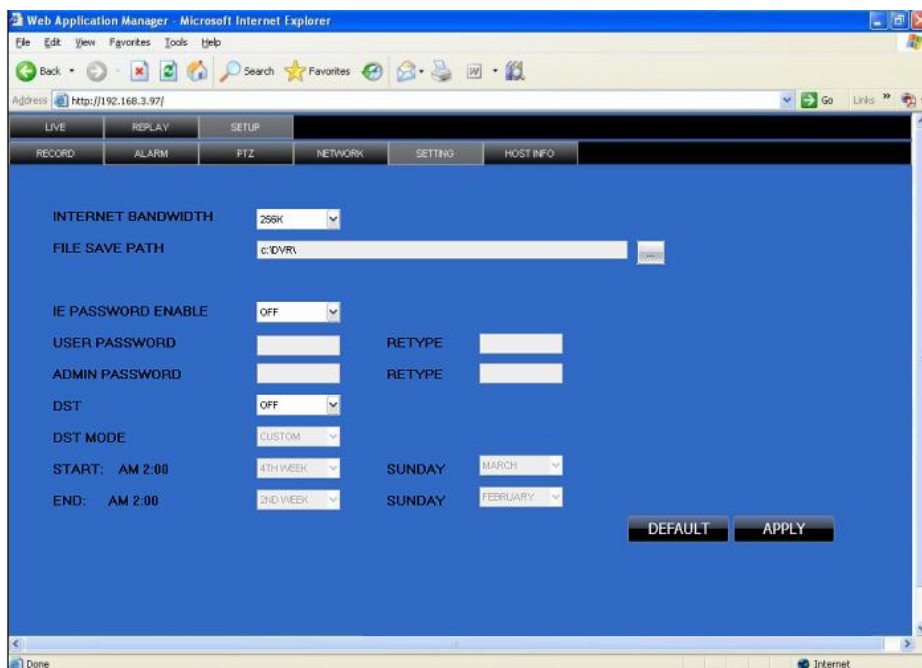

BANDWIDTH: Set the bandwidth in kbps (128k、192k、256k、384k、512k、1024k) that

you want to allocate for traffic that matches the internet. This bandwidth does not include audio.

FILE SAVE PATH: the save path of captured picture and recording video. IE login password and DST settings you can set as DVR setting.

3.3.3.6 HOST INFO

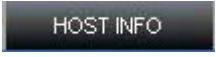
Click  to access system information interface (see below picture).

This interface includes HDD status, remain record time, firmware version and MAC Address. All the information is fixed.

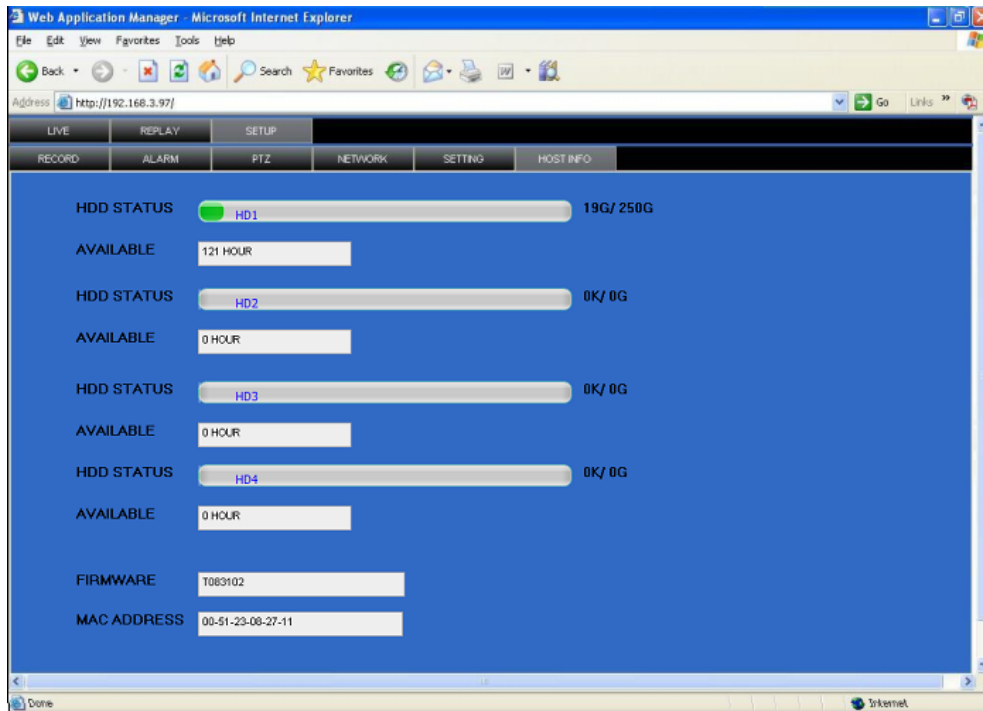

4. DVR INSTALLATION GUIDELINE

4.1 FRONT PANEL

1. THE DEFINITION OF BOTTOMS AND CONNECTORS ON FRONT PANEL

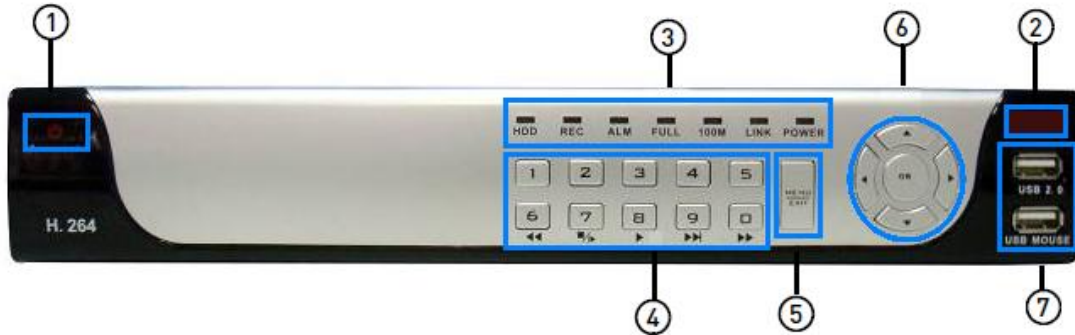

- 1) **Power:** Press to power the system ON/OFF.
- 2) **IR Sensor:** IR receiver for the remote control.
- 3) **LED Indicators:** Shows status of HDD, recording, alarm, network, and power.
- 4) **Channel/Numbers/Playback:** Press buttons 1~4 (4-channel models) or 1~8 (8-channel models) to view the selected channel in full-screen; press buttons 1~0 to input passwords and user IDs; during playback, press the following:
 - 6/◀◀: Increase reverse playback speed 1X, 2X, 4X
 - 7/■▶: Press to freeze playback to one frame, then press again to advance frame-by-frame
 - 8/▶: Press to start playback
 - 9/▶▶: Press to slow playback speed by 1/2, 1/4, 1/8
 - 0/▶▶▶: Press to increase forward playback speed 1X, 2X, 4X
- 5) **MENU/EXIT:** Press to open/close the main menu.
- 6) **Navigation/OK:** Press the Navigation buttons to perform the following:
 - **OK:** In menus, press to confirm selections; in PTZ mode, press to change the navigation buttons to control the connected PTZ camera (not included)
 - ▲: Press to move cursor up; in PTZ mode, press to pan camera up
 - ▼: Press to move cursor down; in PTZ mode, press to pan camera down
 - ◀: Press to move cursor left; in PTZ mode, press to pan camera left
 - ▶: Press to move cursor right; in PTZ mode, press to pan camera right
- 7) **USB:** Connect a USB flash drive to the top port for data backup and firmware upgrades connect a USB mouse to the bottom port.

4.2 REAR PANEL

4-CHANNELS MODEL

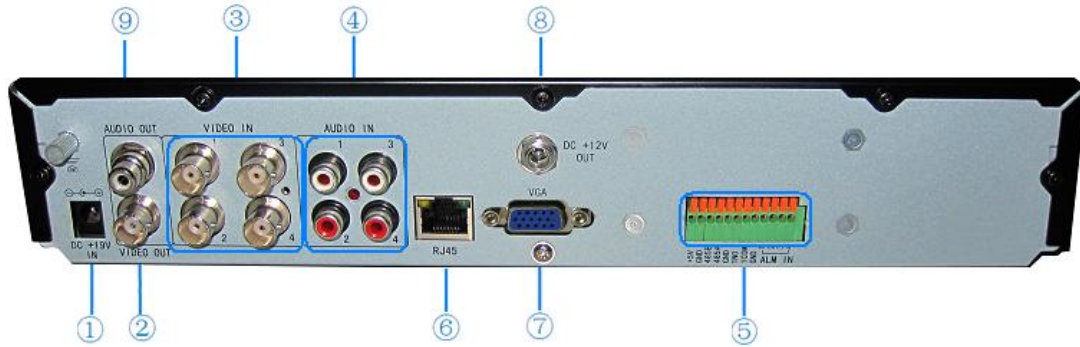

Connectors on Rear Panel

Item	Physical connector	Connector description
1	POWER input	DC 19V/3.42A (3A)
2	Video output	One video output for connecting TV or monitor (BNC)
3	Video input	For connecting analog video signal input (BNC)
4	Audio Input	For connecting audio signal
5 Optional	Alarm Input	4 I/O alarm input
	Alarm Output	I/O output for alarm
	RS485	RS 485 for connecting PTZ
	RS232	For connecting PC
	+12V	Power supply for DC relay and the current is 100MA (make OK short circuit can not happen)
6	Network	For connecting Ethernet
7	VGA output	Optional
8	DC +12V OUT	DC +12@2A power supply for 4 cameras
9	Audio output	For connection audio output

8-CHANNELS MODEL

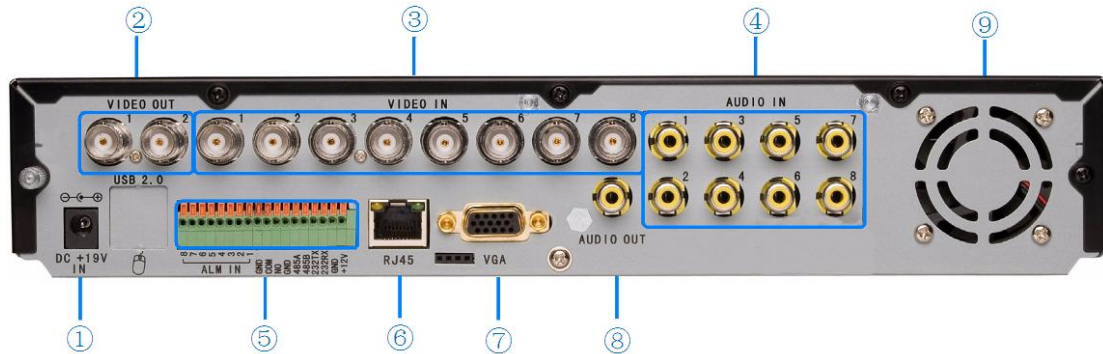

Connectors on Rear Panel

Item	Physical connector	Connector description
1	POWER input	DC 19V/3.42A (3A)
2	Video output	Two video output for connecting TV or monitor (BNC)
3	Video input	For connecting analog video signal input (BNC)
4	Audio Input	For connecting audio signal
5	Alarm Input	8 I/O alarm input
	Alarm Output	I/O output for alarm
	RS485	RS 485 for connecting PTZ
	RS232	For connecting PC
	+12V	Power supply for DC relay and the current is 100MA (make OK short circuit can not happen)
6	Network	For connecting Ethernet
7	VGA output	Optional
8	Audio output	For connection audio output
9	Fan	Please check the fan function for diary maintained and change new one if the fan has some problems

4.3 FULL CONNECTIVITY DIAGRAM

Example: 8channels

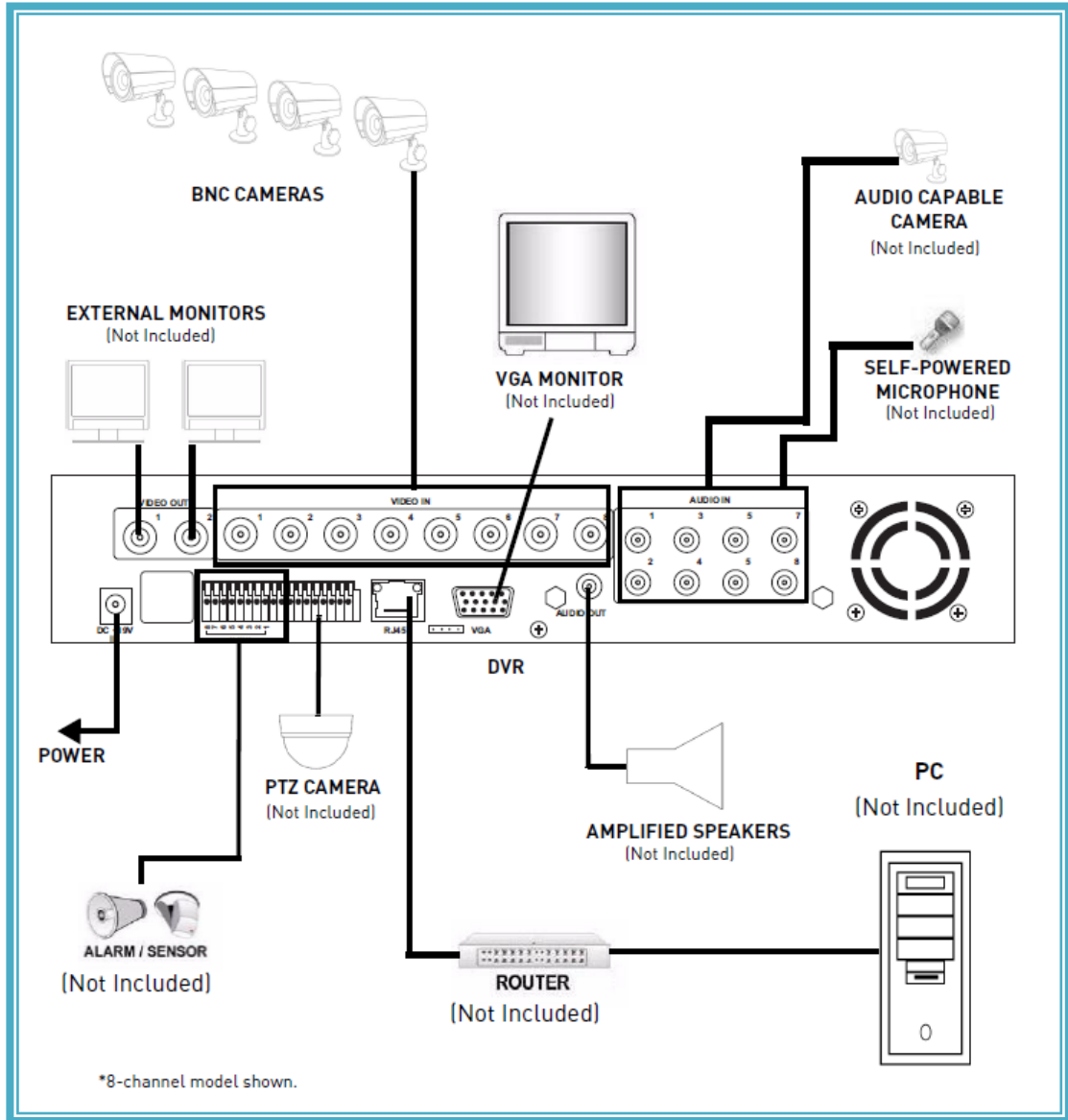

4.4 HDD INSTALLATION

Caution:

When working with electrostatic sensitive devices such as hard disk driver or DVR unit, make sure you use a static-free workstation. Any electrostatic energy coming in contact with the hard disk or DVR can damage it permanently.

Please install the HDD following these steps:

- 1) Open the cover of the DVR and then you will see one HDD plate as follow.

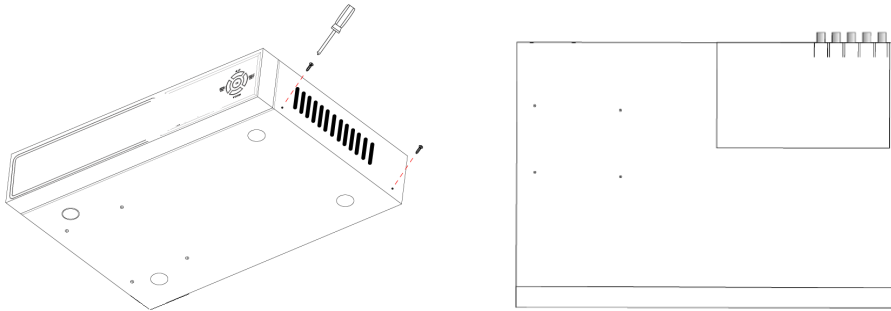

- 2) Connect HDD cables as follow

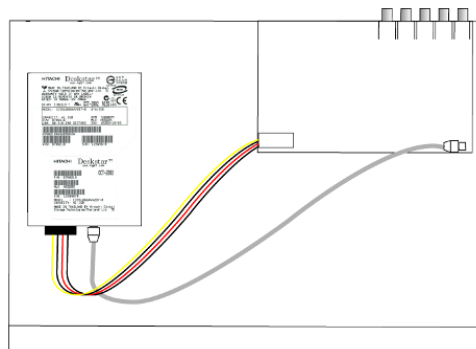

- 3) Affix HDD onto HDD plate as indicated below with the screws provided.

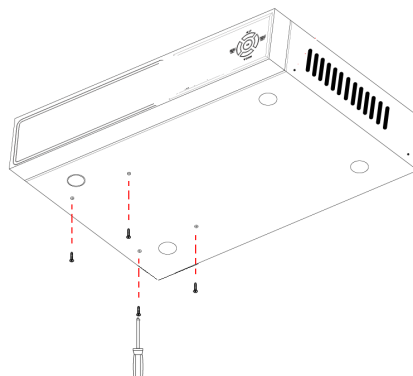

- 4) Install the HDD plate back into DVR and close cover .

Notice: New installed HDD should be formatted before recording.

5. FAQ

If your problem is not listed below, please call our toll-free number for more support.

1. Question: DVR is not working after starting?

Answer:

- ✧ Check the adaptor input
- ✧ Check the on-off power line, is it well-connected?
- ✧ Check the power on-off
- ✧ Check the upgrade procedure
- ✧ Check the main board of DVR

2. Question: DVR is rebooting automatically or stopped after starting the DVR for several minutes?

Answer:

- ✧ Instability or low input voltage
- ✧ Bad track hard drive or the line of hard drive is bad
- ✧ On-off power supply is not enough
- ✧ The front-end video signal instability
- ✧ High temperature, too much dust, too bad the DVR operating environment
- ✧ The main board is not well-connected with other boards
- ✧ The hardware of DVR is defective

3. Question: No output of single channel, multi channel or all channel video?

Answer:

- ✧ Please check the adaptor of camera whether to see if it is well-connected
- ✧ Please check the cable for connecting video input/output in the back panel of DVR
- ✧ Please insert the video source directly into the display device and check if they are causing the problem.
- ✧ Check the brightness of the picture and bring it back to its original default setting
- ✧ No video input signal or too weak
- ✧ Display settings in the preview set to be closed
- ✧ The hardware of DVR is defective

4. Question: DVR cannot record after startup and the interface is showing "H"

Answer:

- ✧ Make OK power adaptor is DC 19V
- ✧ Make OK HDD is formatted
- ✧ Check the power and data connection cables of the HDD
- ✧ The HDD is defective
- ✧ The SATA port is not working

5. Question: What is meaning of "R" "M" "I" "H" showed in interface?

Answer:

- ✧ "R" means the channel is recording

- ◇ “M” means the channel is on motion detection
- ◇ “I” means the channel is on alarm
- ◇ “H” means there is either no HDD. the HDD is bad or the HDD is full

6. Question: DVR is having problem with real-time images, such as bad image color or serious brightness distortion

Answer:

- ◇ If PAL and NTSC is not correctly selected on the BNC output, the images will be in black and white
- ◇ DVR is not compatible with monitor
- ◇ The video transmission distance is too far
- ◇ The setting of DVR color, brightness and so on are wrong

7. Question: No audio sound when monitoring?

Answer:

- ◇ Check sound box or speaker functions. Also check possible short circuit.
- ◇ Audio source may be connected to the video channel. You can click to full-screen to check.
- ◇ The hardware of DVR is defective

8. Question: No audio sound when playing back?

Answer:

- ◇ Setting problem: open audio-video item
- ◇ Check the audio to see if it is closed in playback interface

9. Question: System time is not correct?

Answer:

- ◇ Wrong setting or user did not click "Edit" to confirm
- ◇ Battery is not connected properly
- ◇ Battery is dead. Please change.

10. Question: Why the “Stop recording” by the right mouse button does not work, how to stop recording?

Answer:

- ◇ The “Stop recording” by the right mouse button is only suitable for Manual recording. It can't stop recording when it's in “start recording” or the video in video plan.
- ◇ If you want to stop recording, please set the time is not recording.

11. Question: "Stop recording" function by the right mouse button does not work. How to stop recording?

Answer:

The "Stop recording" by the right mouse button is for Manual Recording only. It can not stop recording when it is in "start recording" or the video is in video plan. If you want to stop recording, please set the time to not recoding.

12. Question: Motion detection is not working?

Answer:

- ◇ The setting of motion detection area is not correct
- ◇ Sensitivity is too low

13. Question: CD-writer /USB backup error

Answer:

- ✧ The data exceeds the capacity of backup device
- ✧ The backup device is incompatible
- ✧ The backup device is damaged

14. Question: Remote control cannot work?

Answer: :

- ✧ The address of remote control is not correct
- ✧ The distance of remote control is too far or the angle is too biased
- ✧ Remote control batteries run out
- ✧ Remote control is damaged or the front panel of DVR is damaged

15. Question: WEB cannot login?

Answer:

- ✧ Please check the network to see if it is connected. Check if LINK or 100M LED is displayed normally on the panel; use ping xxx.xxx.xxx.xxx (DVR IP) to check if the Internet is linked properly.
- ✧ Recommended to use Windows XP or Vista operating system, also use IE6.0 browser or IE7.0 browser
- ✧ ActiveX control has been blocked. Please manually install ActiveX control again.
- ✧ Please install DX8.1 and upgrade your video card driver

16. Question: There is no picture or picture is not clear when you preview the recording or playback the recording via IE

Answer:

- ✧ If you access DVR by IE, please choose "Wan" in "web environment"
- ✧ Please try "Close windows" by the right mouse button, and try "Open windows" again

17. Question: It displays "other members are setting....." while setting DVR by IE

Answer:

- ✧ It probably means someone else is setting the DVR. Please check the DVR configuration interface or exit DVR.

TROUBLESHOOTING

Error	Possible Causes	Solutions
<ul style="list-style-type: none"> System is not receiving power, or is not powering up 	<ul style="list-style-type: none"> Cable from power adapter is loose or is unplugged 	<ul style="list-style-type: none"> Confirm that all cables are connected correctly Confirm that the power adapter is securely connected to the back of the unit
	<ul style="list-style-type: none"> Cables are connected, but system is not receiving sufficient power 	<ul style="list-style-type: none"> Confirm that the system is powered on (LED indicators on the front should be ON) If the unit is connected through a power bar or surge protector, try bypassing the bar and connecting the power directly to the wall outlet Confirm that there is power at the outlet: <ul style="list-style-type: none"> Connecting the power cable to another outlet Test the outlet with another plugged device (such as an electric calculator or phone charger)
<ul style="list-style-type: none"> Remote control is not detected by the system 	<ul style="list-style-type: none"> Battery in the remote control is drained 	<ul style="list-style-type: none"> Install two fresh AAA alkaline batteries in the remote control
	<ul style="list-style-type: none"> There are no batteries in the remote control 	
<ul style="list-style-type: none"> Hard drive is not detected by the system 	<ul style="list-style-type: none"> Hard drive cables are loose or not properly connected 	<ul style="list-style-type: none"> Remove the housing and check that hard drive cables are firmly connected
	<ul style="list-style-type: none"> There is no hard drive in the system 	<ul style="list-style-type: none"> Open the housing and install a 3.5" SATA hard drive
<ul style="list-style-type: none"> Hard drive is full (0%) and the unit is no longer recording 	<ul style="list-style-type: none"> Overwrite is not enabled 	<ul style="list-style-type: none"> From the Main Menu, select HDD>Overwrite>Enable and click Apply

Troubleshooting (cont`d.)

Error	Possible Causes	Solutions
<ul style="list-style-type: none"> • Mouse not detected by system 	<ul style="list-style-type: none"> • Mouse cable is not firmly connected to the system 	<ul style="list-style-type: none"> • Firmly connect the mouse cable to the USB Mouse port on the front panel
	<ul style="list-style-type: none"> • Mouse is not connected to the system 	
	<ul style="list-style-type: none"> • System needs to be reset 	<ul style="list-style-type: none"> • Power off the system (disconnect power cable). Firmly connect a USB mouse to the USB Mouse port on the front panel of the system. Reconnect the power cable to the DC 19V port on the rear panel.
<ul style="list-style-type: none"> • There is no picture on selected channels / camera picture is not being displayed 	<ul style="list-style-type: none"> • Camera cables are loose or have become disconnected 	<ul style="list-style-type: none"> • Check the camera video cable and connections • Disconnect and reconnect the cable at the system and at the camera • Try moving the camera to another channel or use another cable
<ul style="list-style-type: none"> • The image on the DVR appears, but does not have sound 	<ul style="list-style-type: none"> • Audio cables are loose or have been disconnected 	<ul style="list-style-type: none"> • Check the AUDIO connections to the DVR
	<ul style="list-style-type: none"> • Audio channels are disabled in the system menu 	<ul style="list-style-type: none"> • Check the Configurations: Main Menu>Record>Audio
	<ul style="list-style-type: none"> • Volume on external speakers (not included) is low or off 	<ul style="list-style-type: none"> • Increase volume on external speakers (not included)
<ul style="list-style-type: none"> • A "whirring" noise is coming from the system 	<ul style="list-style-type: none"> • Fan is active 	<ul style="list-style-type: none"> • The noise means the exhaust fan is working normally.
<ul style="list-style-type: none"> • The system beeps at startup 		<ul style="list-style-type: none"> • The beep at startup is normal
<ul style="list-style-type: none"> • The system beeps during motion detection 	<ul style="list-style-type: none"> • Motion detection is enabled, but the alarm buzzer is activated 	<ul style="list-style-type: none"> • Open the Main Menu and click ADVANCE • Click ALARM; set the Buzzer to 0s and click APPLY
<ul style="list-style-type: none"> • I am not receiving email notifications 	<ul style="list-style-type: none"> • Email notification is disabled 	<ul style="list-style-type: none"> • Open Main Menu>Advance>Alarm; click EMAIL SETUP; under EMAIL select ON
	<ul style="list-style-type: none"> • Default setting is disabled, but you have not entered your own SMTP information 	<ul style="list-style-type: none"> • If you want to use your own SMTP server, deselect the Default box, and enter your SMTP Server address, Port, User name, and Password in the respective fields