



3D-DNR True Day/Night Weather-proof IR Camera

DC Auto Iris Varifocal Lens(5mm-50mm),(2.8mm-12mm) / IR LED Built-in 98 pcs

NEW



▶ **HD-N1553DNR**
550TV Lines
DC Auto Iris Varifocal Lens(5mm-50mm)
True Day/Night Capability
ICR-IR Cut Filter Removable
850nm IR LEDs * 98pcs

NEW



▶ **HD-N1216DNR**
550TV Lines
DC Auto Iris Varifocal Lens(2.8mm-12mm)
True Day/Night Capability
ICR-IR Cut Filter Removable
850nm IR LEDs * 98pcs

GENERAL FEATURES

- * 1/3" Sony Super HAD CCD
- * Built-In Next Generation 3D DNR with 3D Filter
- * Third-Generation DSP Chip
- * True Day & Night (ICR-IR Cut Filter Removable)
- * External Control Rings for Easy Focus & Distance Adjustment
- * Max. 258X Sens-Up, 0.00001 Lux of Maximum Illumination
- * x32 Digital Zoom
- * D-WDR(Digital Wide Dynamic Range)
- * Vivid Sharp Picture in completely darkness
- * DC Auto Iris Varifocal Lens(4mm-9mm),(3.5mm-16mm)-Option
- * Dual Power(AC 24V/DC 12V)-Option

SPECIFICATIONS

MODEL	HD-N1553DNR/N1216DNR
Sensor	1/3" SONY Super HAD CCD
Total Pixels	NTSC=811(H) * 508(V) / PAL=795(H) * 595(V)
Effective Pixels	NTSC=768(H) * 494(V) / PAL=752(H) * 582(V)
Scanning System	2:1 Interlace
Synchronization	Internal / Line Lock
O.S.D	Available
Dynamic Range	52dB(*128)
Backlight	BLC / HSBL C / Off Selectable
Resolution	550TV Lines(Color), 600TV Lines(B/W)
S/N (Y signal)	52dB (AGC Off, Weight On)
Min. Illumination	0.00001Lux F1.2(Sens-Up * 258X)
White Balance	ATW / AWB / Indoor / Outdoor / Manual / AWC
Electronic Shutter Speed	1/60sec ~ 1/120,000sec
Sense-Up	Auto / Fixed / Off(Selectable limit *2 ~ *258)
Gain Control	High, Middle, Low, Off Selectable
3 DNR	Off/On (1~50 Level Adjustable)
D-WDR	Indoor / Outdoor / Off
Motion Detection	On/Off (4 Zone, Alarm Output)
Privacy	On/Off (8 Zone)
Mirror	Off / Mirror / V-Rev / Rotate
Freeze	On/Off
Sharpness	0~31 (Level Adjustable)
D&N Selection	Color / Auto / Ext / BW
Digital Zoom	On(*32) / Off
Blemish Compensation	256 Point (Even 128 Point, ODD 128 Point)
Power	DC 12V (Dual Power AC 24V / DC 12V)-Option
Power Consumption	CDS ON:1.5A Max
Lens	DC Auto Iris Varifocal Lens(5mm-50mm),(2.8mm-12mm)
Operating Temperature/Humidity	-10°C ~ +50°C(Heater On: -40°C ~ 50°C)
Storage Temperature/Humidity	-20°C ~ +60°C
Dimension	103mm(W) * 108mm(H) * 290mm(D) / 103mm(W) * 108mm(H) * 260mm(D)
Weight	2500g / 2300g

DIMENSIONS

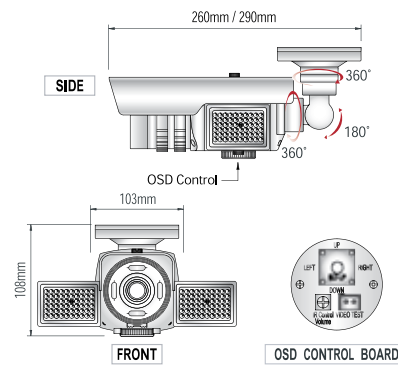

CONNECTION

3-Axis

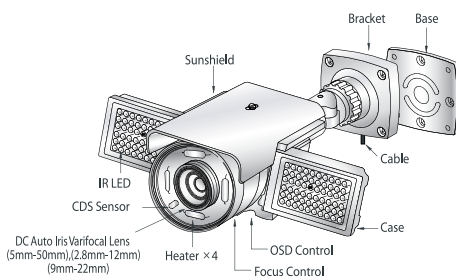

True Day & Night
(ICR-IR Cut Filter Removable)



OSD Control Board

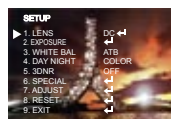

OSD

Built-in 98pcs IR LEDs, it can capture clear images as far as 50~100m away even completely darkness.

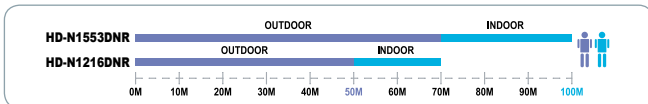

1/3" CCD	DAY & NIGHT	NIGHT DAY FILTER CHANGE	Minimum Illumination 0.00001Lux	Auto White Balance	Sensitivity Up x258	BLC Backlight Compensation
High-Speed Shutter	Motion Detection	OSD	DC VIDEO LENS	550 Horizontal Resolution	Anti Vandal Hood Camera	IP65
						DC 12V AC 24V